

SUBURBIA TRANSFORMED/

Sustainable Drumthwacket



550:439 Suburbia Transformed
Rutgers, The State University of New Jersey
Department of Landscape Architecture

Instructor:
Prof. Holly Grace Nelson

Published 17 December 2018
Cover by Axel Gonzalez
Chapter dividers by Yat Chan and Zhaoxuan Wang

This report was compiled by:

Yat Chan
Robert Cook
Devin Fields
Axel Gonzalez
Eric Graber
Molly Kinghorn
Dianne Lê
Jessica MacPhee
Wes Masco
Tiffany Nguyen
Zoe Orlino
Jessica Thorning
Phia Trinidad
Zhaoxuan Wang

Suburbia Transformed is a 3-credit, junior/senior level course.
It is optional for the BS Landscape Architecture.

Table of Contents/

05/ Introduction

06/ Design Proposals

06/ Devin Fields

12/ Sophia Trinidad

17/ Robert Cook

22/ Molly Kinghorn

28/ Zoe Orlino

34/ Yat Chan

38/ Tiffany Nguyen and
Jessica Thorning

42/ Zhaoxuan Wang

48/ Eric Graber

54/ Jessica MacPhee

58/ Wes Masco

60/ Axel Gonzalez

66/ Dianne Lê

Introduction



Governor Phil Murphy and First Lady Tammy Murphy believe that Drumthwacket could become a showcase for sustainability, demonstrating to the people of New Jersey how a densely populated, suburban state could contribute more to the three pillars of sustainability: social, economic, and ecological. Drumthwacket has served as the Official Residence of the Governor of New Jersey since 1982, yet few governors have lived there full-time to date. The mansion is also an historic house museum and was added to the National Register of Historic Places in 1975. The non-profit Drumthwacket Foundation is responsible for preserving, restoring, and curating the house and the grounds which include, beyond the mansion itself, adaptively restored Italianate gardens; acres of mowed lawn; a restored visitor's center; a large new visitor parking lot; some perimeter woods; and a private area with tennis court, swimming pool and bath house which have fallen into disuse.

This collection of landscape designs for a more sustainable Drumthwacket was produced by fourteen juniors and seniors in the Landscape Architecture Department at Rutgers University. The task of this studio was not to provide engineered solutions, but rather to create different conceptual suggestions for showcasing sustainable landscapes that can be integrated into a future design. The designs represent different ways to achieve sustainability, ranging from more ecological suggestions (increased woodland coverage or using the site to promote options for mowed lawn to promote plant diversity and lowered chemical usage) to incorporating technology (solar energy, ergonomic energy), improving stormwater management, creating wildlife habitat, and expanding plant diversity. Governor Murphy refers to the mansion as "The People's House." This remark struck a chord with many of the students as they considered the social component of sustainability: New Jersey has a long history of immigration and served as a "gateway" from Ellis Island to much of the United States. How do you reconcile greater use of native plant and animal species when much of the NJ population is non-native? The project provided a great opportunity for Rutgers students to think about how they could transform the grounds of a mostly private estate to inspire visitor appreciation for the important principles of sustainability, respectfully adapting and repurposing the site's historical elements while referencing the landscapes and cultural history of New Jersey to create a destination for state functions, school children, local residents, and visitors alike.

The People's Mansion/

Drumthwacket, the official governor's mansion of New Jersey, possesses the title "The People's House". However, the current design does not fully reflect the democratic title it represents itself as. This design takes inspiration from the application of democratic values to formal gardens; a mixture of Italianate, French, and English gardens create four primary axes with specific themes and purposes.



Schloss Benrath

Castle Benrath, located in Dusseldorf, Germany, is the main inspiration behind my design which preserves existing axes and creates new ones. The interaction between formal axes and sinuous paths already existed in the design of Drumthwacket. However, they were misused and misrepresented. Creating more views from the axial paths and giving them purpose makes the landscape not only more beautiful, but practical.



Duke Farms

Duke Farms, located in Hillsborough, NJ, was the case study that inspired the aspects of sustainability and texture in my design. Duke Farm's sustainable parking lot and community farm were inspiring examples. Also, the textures of meadows, dense gardens, trial gardens, and hardscape materials all play a part in this design for Drumthwacket.

Benrath Axis Diagram

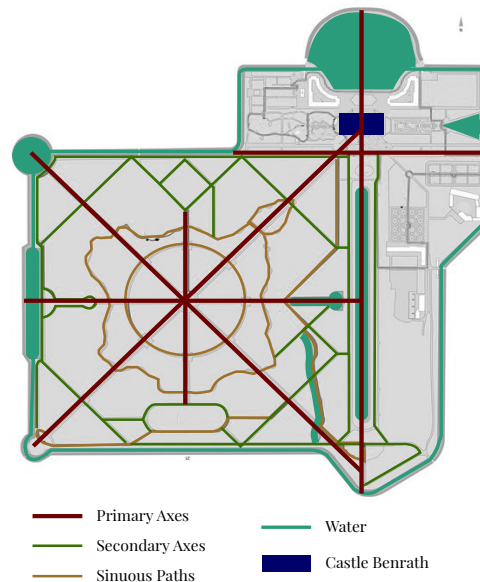

Drumthwacket Axis Diagram

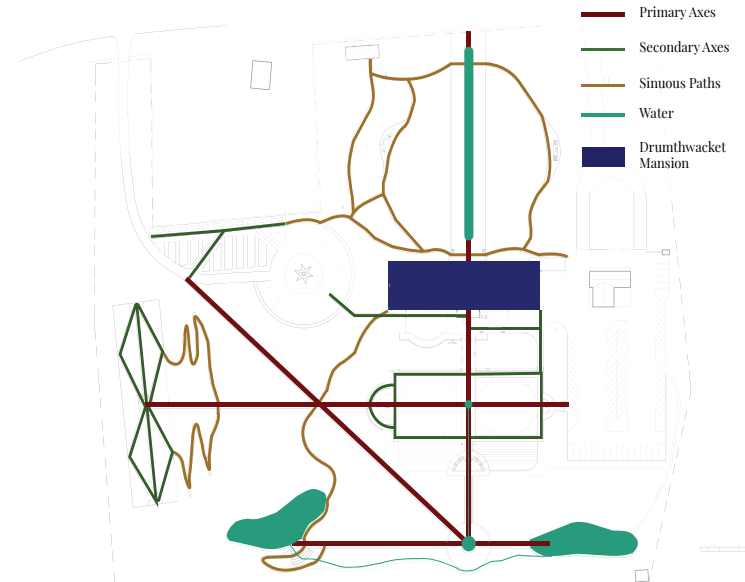



Original Scale: 1" = 30'

Themed Garden Axes/

CO-CREATION

a way of working together where people from different backgrounds are invited to jointly produce a product or service that will benefit all of them

COMMUNITY FARM

A place of co-creation, ran by the Drumthwacket Foundation, where local residents can come and help grow vegetables, fruits, and other plants.

LIVING LABS

Multiple plots along the axis dedicated to studying the landscape and the organisms that inhabit it to learn, teach, and provide solutions to problems.

SOCIALIZATION

the means by which social and cultural continuity are attained

REFLECTING POOL & FRONT MEADOW

Historically, fountains and pools are centerpieces to public places, and promote socialization of all people. The people's house should reflect this, both literally and figuratively.

THE LAWN

In the Italianate garden, formal hedges frame the two lawns to create a destination to sit and enjoy the formality of the historic garden. It can also be a place to host events under a tent.

INTERSECTION | FROG PONG

The historic frog pond is converted into a gathering space with more space for seating and historic/educational signage describing the garden and the sustainable practices surrounding the space.

CO-HABITATION

the state or fact of living or existing at the same time or in the same place

NATIVENESS TRIAL GARDEN

A place of study where non-native and native plants are planted in formal rows facing one another to show the comparison between the two, and how they, like the diverse immigrants who who have populated N.J. are not so different.

NON-NATIVE FOREST

Between the ADA accessible paths is a densely planted forest of non-native shrubs and small trees that is hidden by the tall meadow and is meant to be found and experienced.

INTERSECTION | EDUCATIONAL TERRACE

The intersection of co-creation and co-habitation discusses the research done along these two axes and how plants and people of different origins can co-exist in this state.

SUSTAINABILITY

avoidance of the depletion of natural resources in order to maintain an ecological balance

RETENTION AMPITHEATER

Built into the meadow hill, the ampitheater hosts performances open to the public or educational lectures on sustainability, best management practices, and living lab studies

FORESTED RETENTION POND

Deep in the southeast corner is a retention pond with an overlook for guests to visit, spend time within, and read about the purpose of the retention pond relating to the stormwater runoff from the parking lot.

THE STREAM

The existing stream in the southeast corner of the property is redirected to flow from the parking lot, to the forested retention pond, and overflow to the larger amphitheater pond. The plants alongside it clean the water as it flows past.

Nativeness Trial Garden/



Meadow & Front Lawn/



Plant Palette: Native/

ALLEGHENY SERVICEBERRY

Amelanchier laevis

According to Longwood Gardens, Allegheny Serviceberry is a perfect tree to grow in meadows because of its quick growth and beautiful white flowers.



COMMON BLUE VIOLET

Viola sororia

As New Jersey's state flower, common blue violet is a perfect plant to study in the nativeness trial garden. A perfect control to compare how non-native plants grow, attract pollinators, etc.



GOLDENROD "FIREWORKS"

Solidago rugosa

A tall meadow plant that will fill the meadow with a bright yellow color and bring various pollinators to the meadow.





REED CANARY GRASS

Phalaris

arundinacea

Reed Canary Grass is a 2-6' high perennial that has multiple subspecies, some native and some non-native. In the trial garden, the non-native species can be studied, while the native species can mix in with the meadow grasses.



HONEYSUCKLE VINE

Lonicera

spp.

A perfect vine for the terrace in the nativeness trial garden because of its rich history in the US. Marked as a non-native invasive species in the US, its beauty hides this fact. Visitors can stand under it and read more about non-native species.



CHINABERRY TREE

Melia

azedarach

Native to Southeast Asia and northern Australia, the Chinaberry Tree has become naturalized in the southeastern US. A small ornamental tree that could fit well in the dense non-native forest.

at odds with ECONATIONALISM/

Eco Nationalism historically is defined as a desire to eliminate reliance on foreign sources of fuel and energy. However, the rise of social movements has highlighted the connection between US nationalism and conservationists' obsession with native plants. When the focus is so heavily centered on native plants, we as a nation enforce nationalistic ideals within our culture, and we as designers miss out on the indigenous knowledge embedded in our land and the flora of the nations of our immigrants. Studies of Ethnobotany inherently oppose Eco Nationalism; when the focus shifts to traditional knowledge and the celebration of this knowledge we create a new narrative of inclusivity and open the doors for non-native plants that can be beneficial and integrated in our landscapes.

We Are Still Here!

Drumthwacket, the residence of the governor, is meant to be the residence for all people. This is an impossible task when some members of our New Jersey landscape are rendered invisible or actively targeted by colonial tradition or by our current administration's legislative policies. Landscape is inherently tied to the people that surround it and exist within it. This design is intended to work with the concepts of Ethnobotany to push back against the ideas of Eco Nationalism by celebrating the parts of New Jersey that are often ignored but cannot be separated from its culture and ecology. This plan includes landscapes inspired by Indigenous peoples' knowledge, and also includes flora from the landscapes of our immigrants. Landscapes to celebrate the folks that are too often not considered as New Jersey and US citizens are not the solution to the generational traumas imposed onto them by colonialism and the nationalism, but visibility is a good place to start.

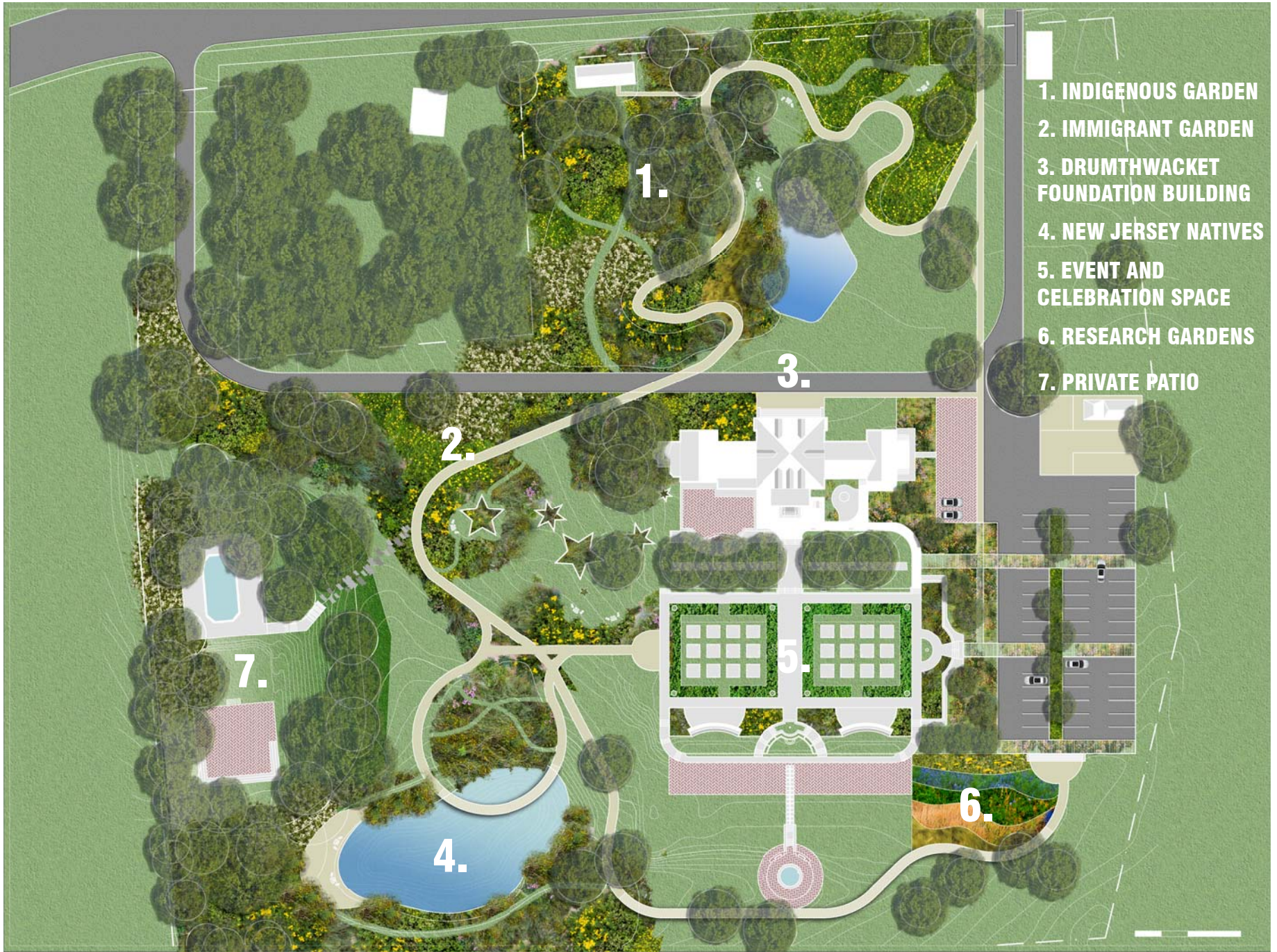

- 1. INDIGENOUS GARDEN
- 2. IMMIGRANT GARDEN
- 3. DRUMTHWACKET FOUNDATION BUILDING
- 4. NEW JERSEY NATIVES
- 5. EVENT AND CELEBRATION SPACE
- 6. RESEARCH GARDENS
- 7. PRIVATE PATIO

IMMIGRANT GARDEN/



1 in 5 residents in New Jersey are immigrants, while 1 in 6 have at least one immigrant parent. The top countries of origin of immigrants in New Jersey are:

| | | |
|-------------|----------|---------|
| India | | (12.5%) |
| Dominican | Republic | (8.4%) |
| Mexico | | (6%) |
| Philippines | | (4.5%) |
| Korea | | (4%) |

INDIA

**DOMINICAN
REPUBLIC**

PHILIPPINES

KOREA

MEXICO

INDIGENOUS GARDEN/



There are four NJ State Recognized Indigenous Tribes: Nanticoke Lenni-Lenape, Powhatan Renape Nation, Ramapough Lenape Indian Nation, and Intertribal American Indians of NJ. This Indigenous Garden focuses on flora that Lenape Tribes have used for medicinal purposes.

BOX ELDER



REDBUD



BLOODROOT



PRICKLY PEAR



CATTAILS



BLACKBERRY



Sustainable Drumthwacket and the “New Lawn”/

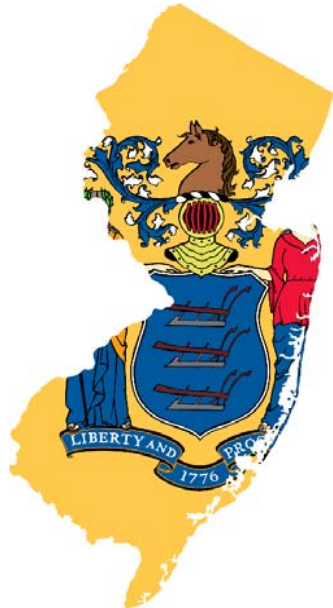

Integrating Best Management practices and making sustainable decisions in the landscape can decrease storm water runoff and non point source pollution from pesticides and fertilizers used in lawn care. Through Drumthwacket’s redesign, it is possible to redefine the suburban lawn.

The Average Lawn is mowed 30-40 times a year. Because they are usually non-native cool season grasses, they require a lot of maintenance to keep them looking green and healthy. Expensive fertilizers, herbicides, and insecticides are applied which contain toxic chemicals and heavy metals.

One alternative to the turf lawn is the Perennial Meadow--a beautiful, naturally occurring landscape that only needs to be mowed once per year. Once established, meadows require few pesticides and little watering so more of the maintenance effort can be placed towards keeping other areas of Drumthwacket neat and tidy. Visitors will see the beauty and rewards of having a “New Lawn”.

Site Analysis/



The site contains a healthy mix of trees and vegetation. Some trees are very old and quite large. The topography varies a lot with flat areas of lawn, and steep grades that lead to a pond. There is a swimming pool that has not been maintained for a long time as well as a clay tennis court.

A recent addition of a large parking lot is causing erosion issues and the lack of trees is unsightly to neighbors sharing backyard views.

While Drumthwacket has had a history with formal plantings and an Italianate garden, and a private estate, the times and uses of the Governor's residence are changing.

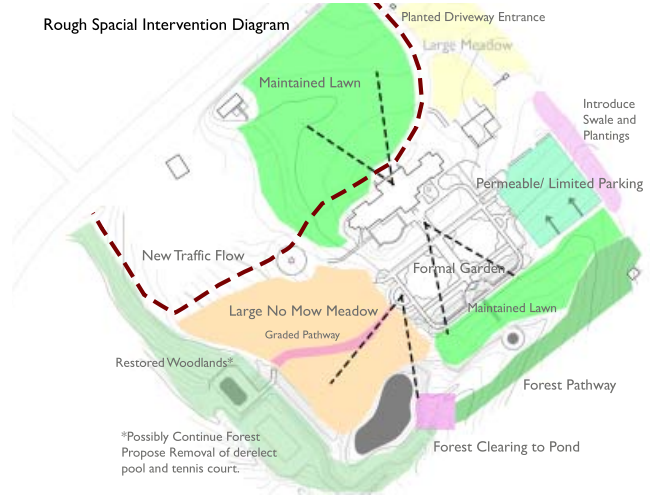
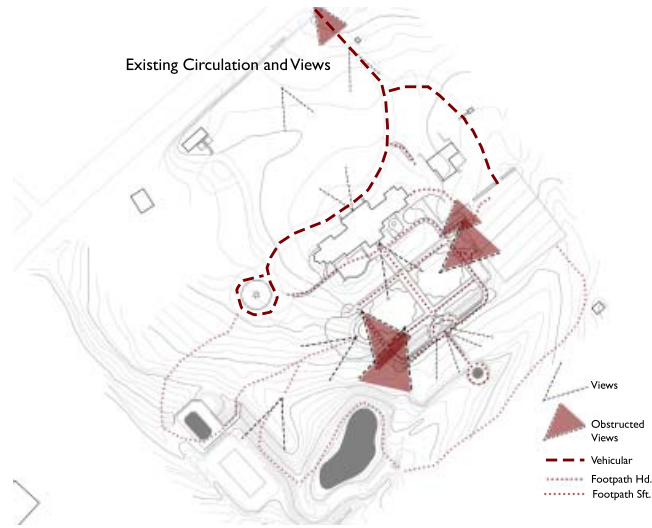

Master Plan/

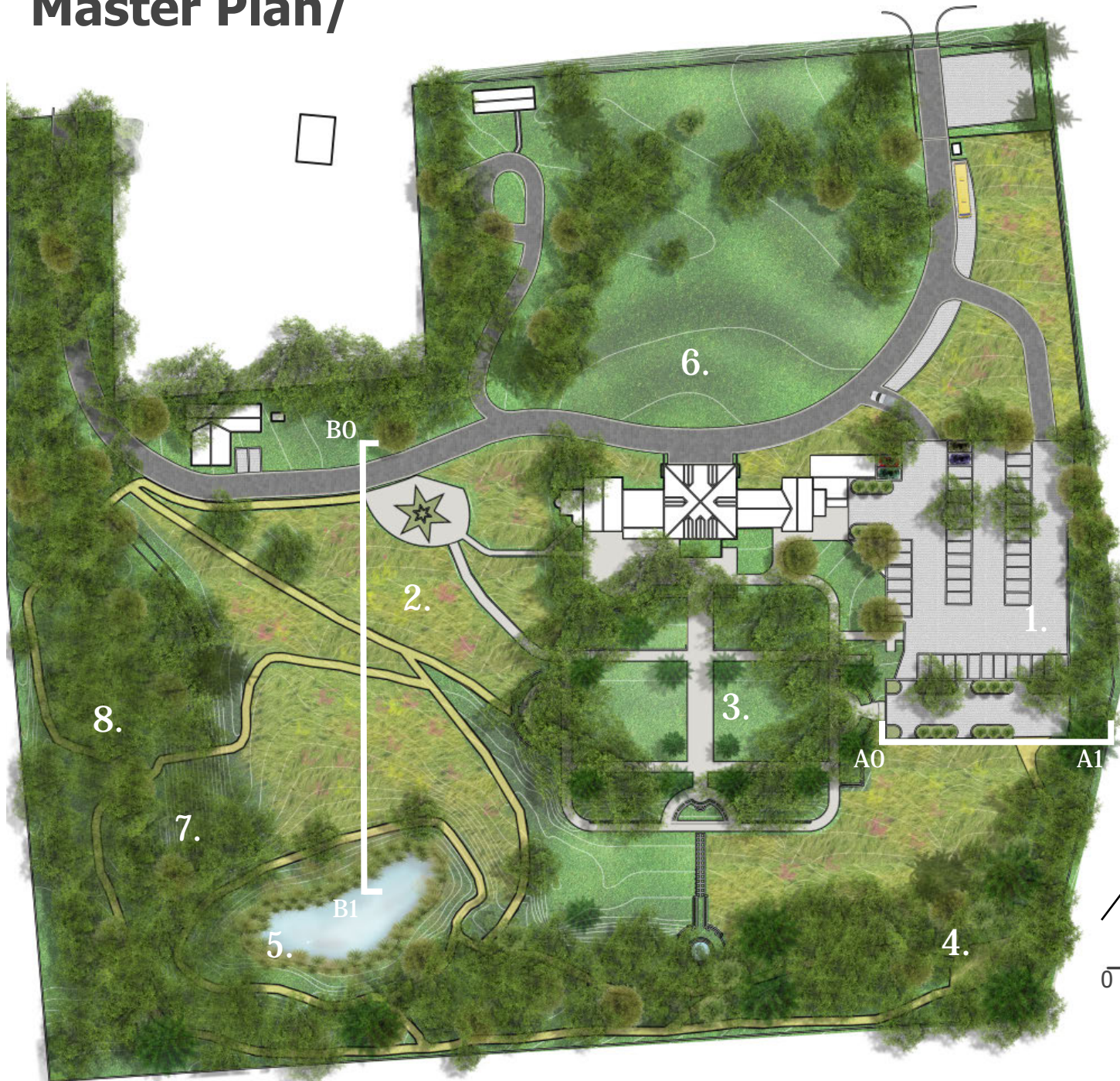

Spatial Usage Diagram



Total 10.9 Acres:
 Implement:
 Meadow 2.74 Acres
 Expand Forest to 3 Acres
 Shrink Lawn to 2.5 Acres
 Shrink Parking Area from .85 Acre to .50 Acre.

Implement:
 Permeable Parking Lot
 Capacity 40 Spaces
 Bus Parking Pulloffs

Key/

1. Parking Lot
2. Perrenial Meadows
3. Italianate Garden
4. Woods Path
5. Wetland/ Pond
6. Lawn
7. Winterberry Grotto
8. Restored Woodland

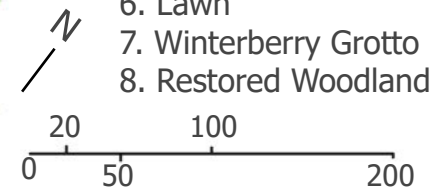

Sections/

Section A



Section B

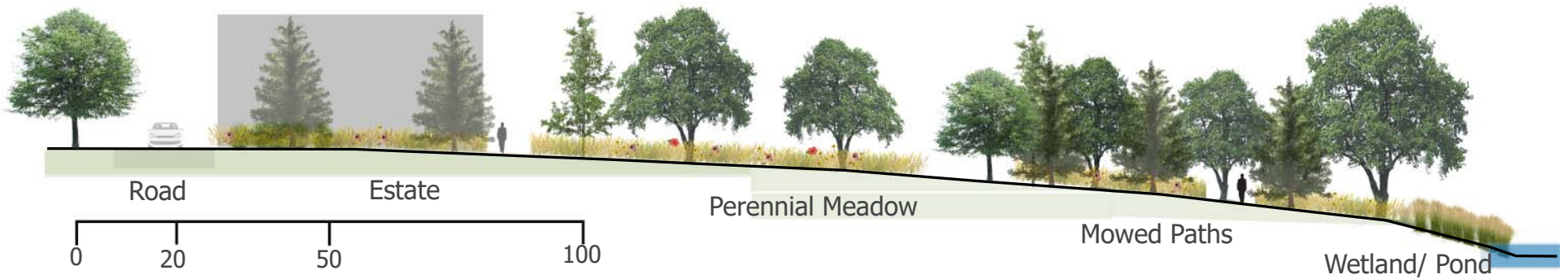

Perspectives/



1. Winterberry Grotto at Tennis Court

2. Current parking vs. proposed meadow.

3. Restored woodland fence edge.

Lawn Management

At present, the estate is mostly mowed lawn: Drumthwacket has an existing 5.9 Acres of lawn. By reducing it to only 2.5 Acres, time, cost and effort could be saved in maintaining the estate. No-mow areas would no longer require constant mowing from contractors or staff. This greater plant diversity would be an ecological investment.



The Landscape can be used as an educational canvas exhibiting the new economically and ecologically sensible way to re-envision a large lawn area. While not everyone can create a perennial meadow, it will raise awareness on the importance of natural recharge zones and wetlands and New Jersey's arising challenges with so much impermeable infrastructure and the water issues associated with that. Visitors to Drumthwacket will see the difference between a classic lawn and a low maintenance perennial meadow, including pops of color and seasonal interest as well as habitat creation.

If you were to fertilize Drumthwacket's existing 5.9 acres of lawn you would need to dump about about 803 lbs of (Scotts Turfbuilder) 32-0-10 fertilizer on the ground. If this is done twice yearly it would cost about \$1500 and end up being almost 1 ton of fertilizer contributing to non-point source pollution which runs into our waters.



The Design proposed uses landscape elements from the practices at North Creek Nursery. Meadow plantings, different textures, rewilding the pool area, planting steep and eroding slopes, wetland restoration and the addition of pollinators.

Drumthwacket: A Celebration of Culture in the Landscape/

Drumthwacket has a rich historical and cultural past that has been lost in recent years. Each elected governor has the choice to live in this mansion, the center piece of the entire site, but this option does not always seem like the most appealing due to the degradation of the house over time. In order to allow Drumthwacket to rise to it's fullest potential, the private aspect of the site must be eliminated to convert the site into a fully public attraction. By making this shift, the possibilities of the site open up to allow for smarter design and would foster a stronger connection between Drumthwacket and New Jersey residents. The money spent updating the upper level of the mansion could be redirected towards a public-friendly garden design in order to establish Drumthwacket as a destination rather than a hands-off feature of New Jersey.



- Remove
- Highlight



Plan/



- Water
- Meadow
- Mulch Path
- Gravel
- Greenhouse
- Brick Paving
- Boardwalk
- Asphalt



Case Studies/

Storm King Wavefield
(Maya Lin)
Windsor, NY



These iconic waves were a source of inspiration for my topographic design in the south lawn. I am using this form to represent the waves that carried countless immigrants to the eastern shores of the United States and eventually to settle in New Jersey.

Duke Farms
Hillsborough, NJ



The visitor dropoff circle planting in front of the mansion at Duke Farms gives the entrance a very grand impression, which inspired trying something similar at Drumthwacket. The entrance sequence into Drumthwacket will be highlighted by relocating the Star Circle to be centered on the mansion.

Historic Drumthwacket
Princeton, NJ



I drew inspiration from several historic elements of Drumthwacket. The fountain will be brought back to bring a new focal point to the formal garden. The historic gazebo becomes a lookout branching off the boardwalk that encircles the pond.

Details/

I chose to implement several sustainable practices into my Drumthwacket redesign. I replaced the large impervious parking lot with parking spaces along the extended driveway, reducing impervious surface and improving site drainage by using gravel instead of asphalt. The visitor would exit onto a path flanked by a rain garden bioswale to catch additional runoff. Replacing the old parking lot, the design features a functional greenhouse for year-round crop production to showcase at government functions.

A forest path connects to the greenhouse area, taking guests through the back woods, and past the Frog Pond. They emerge from the woods to walk around the pond on a boardwalk with a 360 degree view of the site. Surrounding the pond will be a tall meadow to showcase the diverse native plants that can be found across New Jersey and meld into the rolling hills adjacent to the pond.



Perspective of Greenhouse



Section

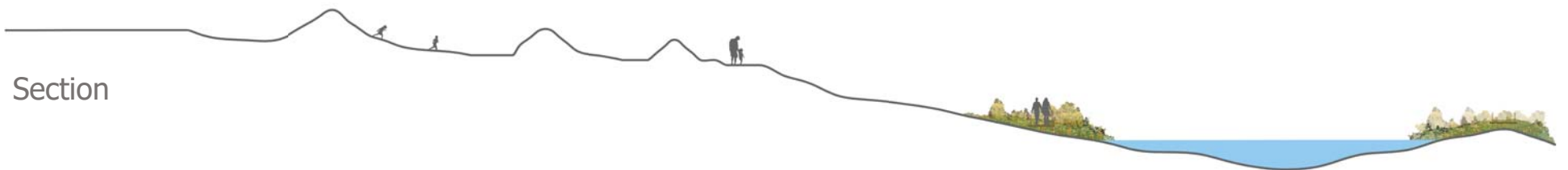

Immigration in New Jersey/

The proposed 'waves' that sit next to the pond each represent one of the five largest immigrant populations in New Jersey. On each wave, the visitor finds plants native to that country of origin. By choosing to make a statement about embracing diversity in New Jersey through non-native plantings, I am challenging the current stigma that surrounds non-native plants. There exists a blind skepticism about non-native plants that should not only be challenged but celebrated in non-native gardens that showcase the diversity we find in our state. This statement can mirror the contemporary issue of immigration and the stigma that surrounds it. New Jersey is a diverse state with high rates of immigration, and a garden at Drumthwacket that glorifies this aspect of our state could go beyond garden design. This design could set the example for how we feel about immigration in our state and our country.

India

- Indian Mahogany (*Swietenia mahagoni*)
- Garden Asparagus (*Garden Asparagus*)
- Eucalyptus (*Eucalyptus globulus*)
- Aloe Vera (*Aloe barbadensis*)
- Tulsi (*Ocimum tenuiflorum*)
- Cork Tree (*Phellodendron*)
- Tumeric (*Curcuma longa*)

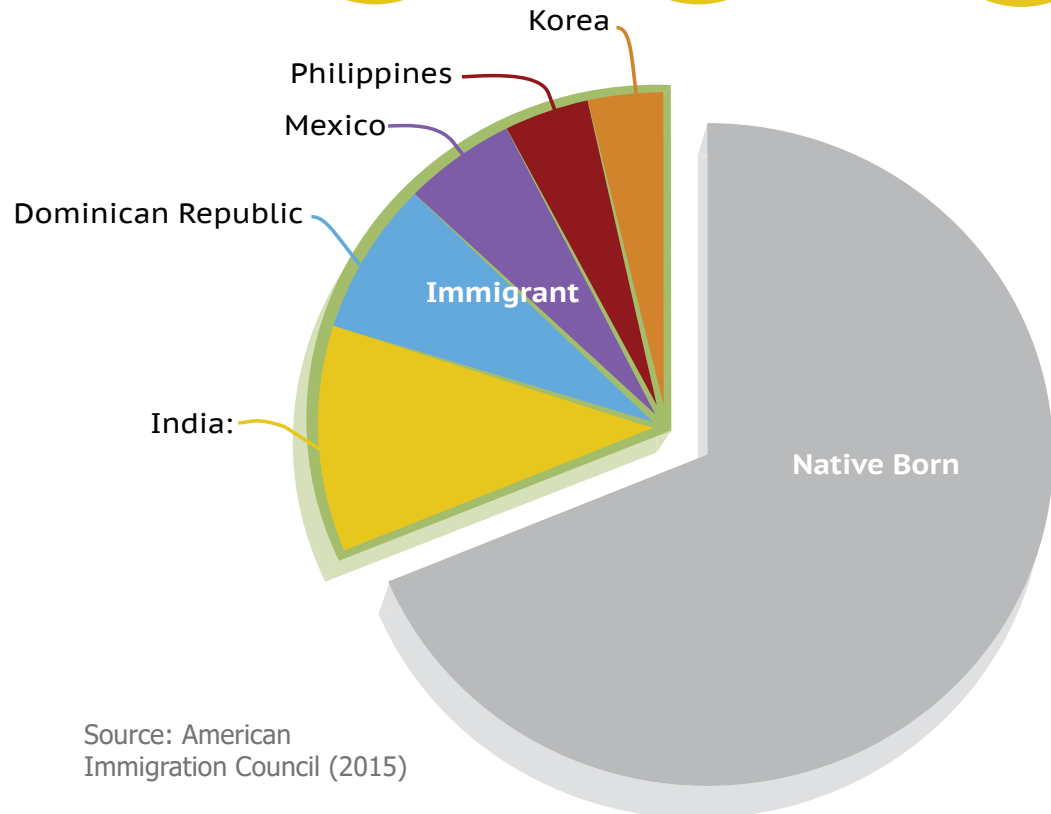

Source: American Immigration Council (2015)

Dominican Republic

Bayahibe Rose (*Pereskia Quisqueyana*)
Coabo (*Swietenia macrophylla*)
Sweet Cherry (*Prunus avium*)
Coralillo (*Hamelia patens*)
Saman (*Samanea saman*)



Mexico

Mayfield's Sunflower (*Conoclinium mayfieldii*)
Thompson's Yucca (*Yucca thompsoniana*)
Mexican sycamore (*Platanus mexicana*)
Mexican Bush Sage (*Salvia leucantha*)
Brushholly (*Xylosma flexuosa*)
Agave (*Agave americana*)
Allspice (*Pimenta dioica*)



Philippines

Attenborough's Pitcher Plant (*Nepenthes attenboroughii*)
Cebu Cinnamon Tree (*Cinnamomum cebuense*)
Philippine Teak (*Tectona philippinensis*)
Almaciga (*Agathis philippinensis*)
Taxus (*Taxus sumatrana*)



Korea

Korean rhododendron (*Rhododendron mucronulatum*)
Korean abelialeaf (*Forsythia Korean Nakai*)
Siebold's magnolia (*Magnolia sieboldii*)
Manchurian cherry (*Prunus maackii*)
Hibiscus Syriacus (Rose of Sharon)
Ginkgo (*Ginkgo biloba*)



History through Gardens/

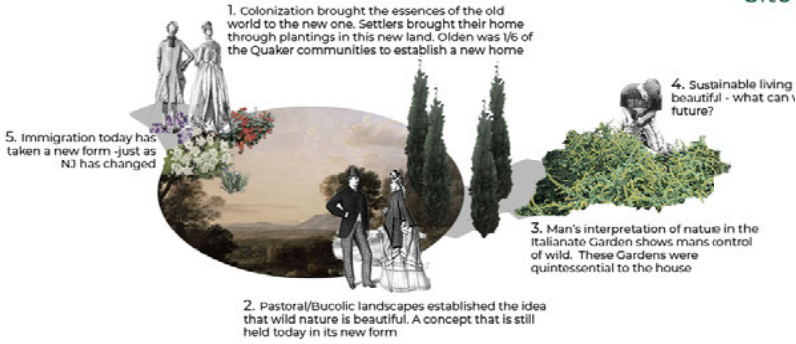

In this Drumthwacket design proposal, the use of historical garden design typologies, such as the Colonial and Italianate gardens, reveal the history of New Jersey through their plantings and forms. The journey a user has through the Colonial, pastoral, and sustainable gardens describes how New Jerseyans saw nature and beautiful across time. Here, the gardens tell this history.

Diagrams to the right compare the existing and proposed use of spaces, concentrating and curating the different zones in a more sensible way based on user experience.

Existing Site Analysis of Site Zones/ People's Spaces

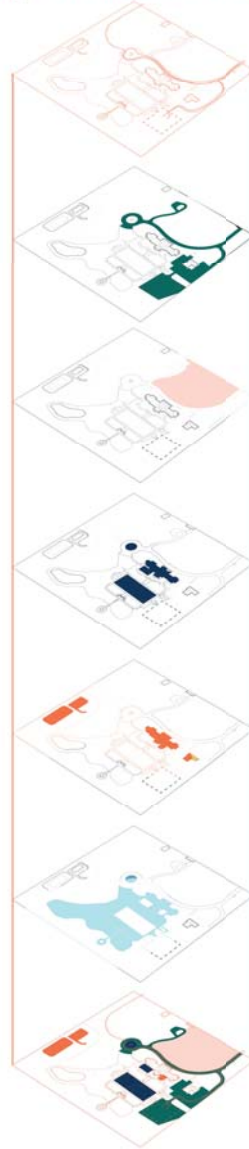

Road Circulation

Road

Green Space

Event Spaces

Governor's Private Spaces

Visitor's Spaces

Combine Anaylsis

Proposed Site Analysis of Site Zones/ People's Spaces



Road Circulation

Road

Green Space





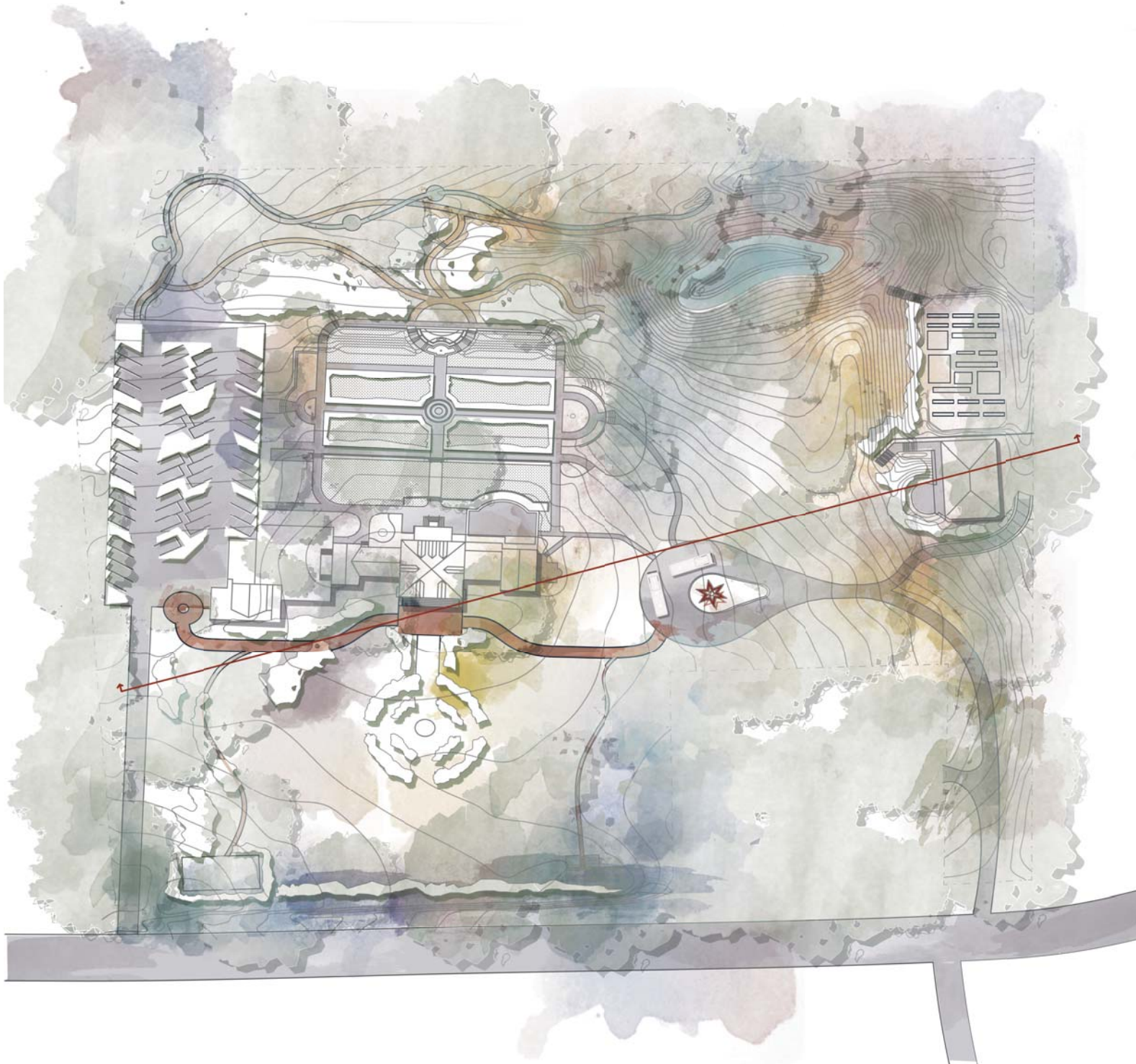

Event Spaces

Governor's Private Spaces

Visitor's Spaces

Combine Anaylsis



-  Paved Path
-  Tree
-  Water
-  Road/Asphalt
-  Dirt Path
-  Planting

Section with Sustainability Examples/



Rain gardens collect storm water runoff and carry it towards the nearby stream for further filtration



Sustainable (rain, pollinator, etc..) gardens are on display for visitors to draw inspiration from for their own homes

Perspectives of the Garden Typologies/



Pastoral Garden:
the idea of rural, wild, and native nature



Colonial Garden:
where the sundial and fragrant (medicinal)
plantings take you to the early era of America



Sustainability Demonstration Gardens:
where you can take the knowledge of a sus-
tainable, greener future home to your per-
sonal garden

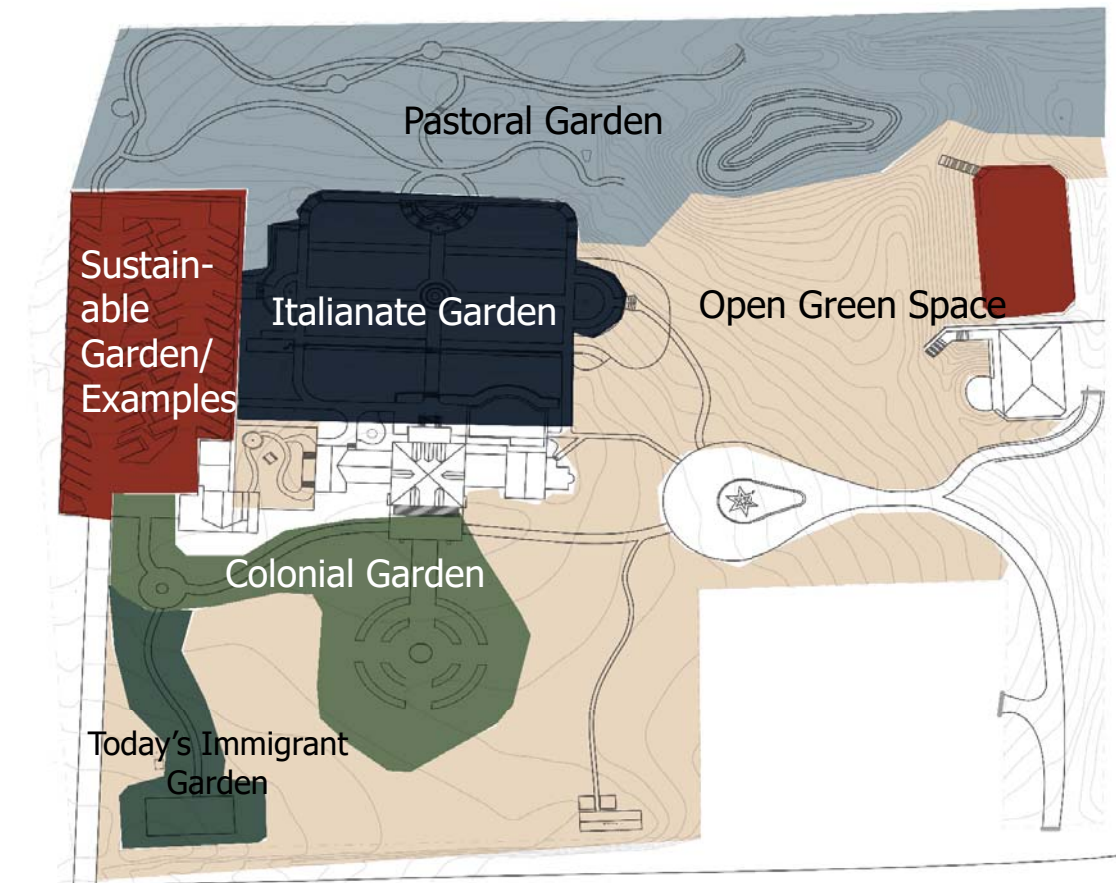

Garden Types/

Colonial Garden

Hollyhocks (*Alcea rosea*)
 Hyssop (*Hysoppus officinalis*)
 Oregano (*Origanum vulgare*)
 Lady's mantle (*Alchemilla mollis*)
 Hyssop (*Hysoppus officinalis*)
 iris plants (*Iris spp.*)
 Mugwort (*Artemisia vulgaris*)

Immigration Garden

Japanese Hydrangea Vine (*Schizophragma hydrangeoides*)
 Ice Dance Japanese Sedge
 (*Carex morrowii* 'Ice Dance')
 Visions in Pink Chinese Astilbe (*Astilbe chinensis* 'Visions')

 Caladium humboldtii (elephant ear)

Italianate

Boxwoods (*Buxus spp*)
 Italian Bugloss (*Anchusa azurea*)
 Italian cypress (*Cupressus sempervirens*)

Pastoral

Southern Red (*Quercus falcata*)
 Black Gum (*Nyssa sylvatica*)
 Atlantic Whitecedar (*Chamaecyparis thyoides*)
 Karl Foerster Grass (*Calamagrostis x acutiflora* 'Karl Foerster')

 Tufted Hair Grass (*Deschampsia cespitosa* 'Schottland')

Sustainable Garden

Rain Garden

Silky Dogwood (*Cornus amomum*)
 Swamp Milkweed (*Asclepias incarnata*)
 Prairie Cordgrass (*Spartina pectinata*)

Pollinator Garden

Butterfly Milkweed (*asclepias tuberosa*)
 white heath aster (*Symphotrichum ericoides*)
 Cranesbill (*Geranium* 'Azure Rush')
 Smooth Oxeye (*Heliopsis helianthoides* var. *scabra*)

Gardening Drumthwacket/

Three main components of sustainability are society, economy, and environment. This design contains gardens planted with low maintenance perennials; a social sustainability garden that includes different kinds of non-native but not invasive plants represents the different ethnicities in the big American melting pot; and a New Jersey Geological Garden embraces the beautiful regional New Jersey plant communities.

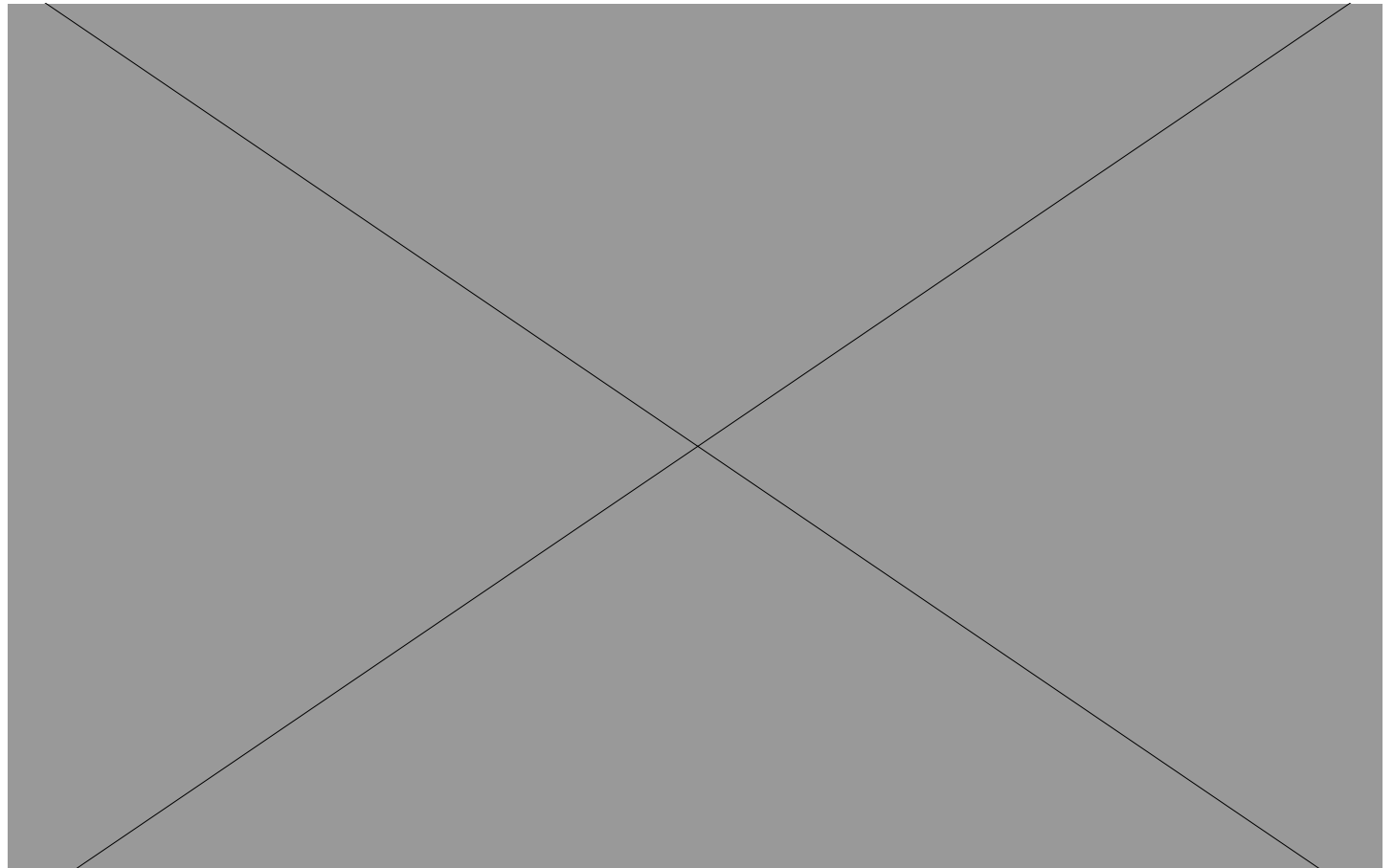

Concept/

Walking from the parking lot, a rain garden welcomes visitors and collects storm water from the parking lot. Visitors can walk down along the Japanese Maple trail along the stream in order to get to the existed water structure and another rain garden. Then, visitors can walk up to the Italianate garden, enjoy a view of the social sustainability garden from the platform, or follow a walkway that would actually lead visitors there.

The social sustainability garden around the pond celebrates plants from varied countries, and its noninvasive non-native are not difficult to maintain. This brings out an important message that peace is not everyone having the same culture, it is everyone having different culture but also respecting one another.

Next, visitors can go to the Geological Garden of New Jersey. New Jersey geology is made of Ridge and Valley, Highlands, Piedmont, Inner Coastal Plain, and Outer Coastal Plain. Visitors can experience being in different geological regions, and learn more about New Jersey environmental history.

Lastly, this design's purpose is to raise awareness of environmental protection and a sustainable future.

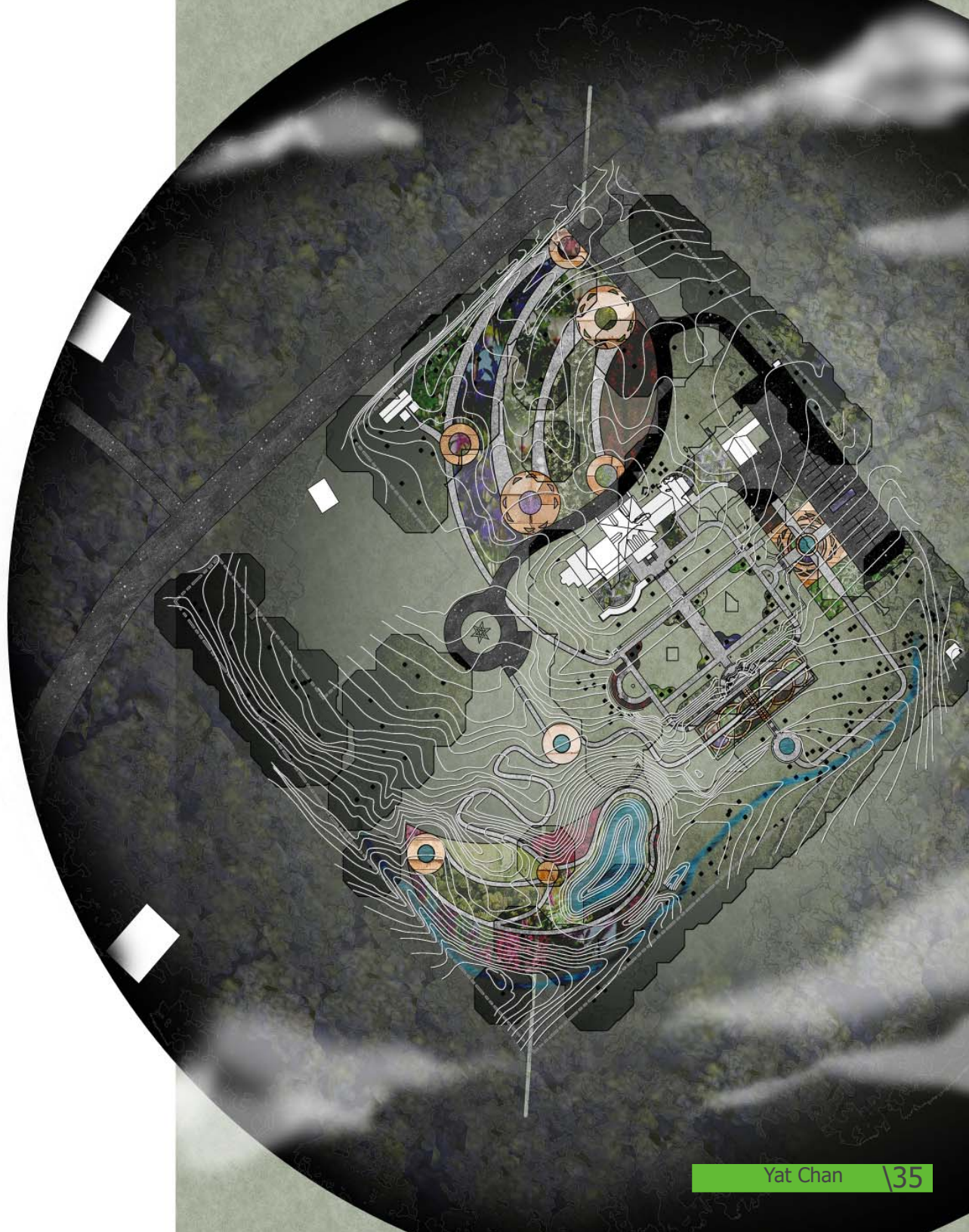



Gardens/

Geological Garden

Ridge & Valley:
Monarda fistulosa
Monarda punctata

Piedmont:
Liatris pilosa
Liatris scariosa
Liatris spicata

Outer Coastal Plain:
Asclepias incarnata
Asclepias syriaca

Highlands:
Baptisia australis
Baptisia tinctoria

Inner Coastal Plain:
Solidago caesia
Solidago canadensis
Solidago rugosa

Feature:
Plant Zone 6
Herbaceous Perennial
Low Maintenance
Above 2 feet
Uses for Rain Garden

Social Sustainability Garden

Angelica archangelica
Astilbe chinensis
 'Diamonds and Pearls'
Astilbe chinensis
 'Love and Pride'
Lobelia × speciosa

Lobelia 'Purple Towers'
Lobelia 'Rose Beacon'
Lobelia 'Ruby Slippers'
Nuphar lutea
Persicaria amplexicauli
Saururus Chinensis

Additional Feature:
Non-native
Not Invasive

Rain Garden

Amsonia hubrichti
Aruncus dioicus
Iris 'Caesar's Brother'
Polygonatum odoratum
 var. *pluriflorum* 'Variegatum'

Lobelia cardinalis
Melanthium virginicum
Hibiscus 'Blue River II'

Additional Feature:
Plant of Merit

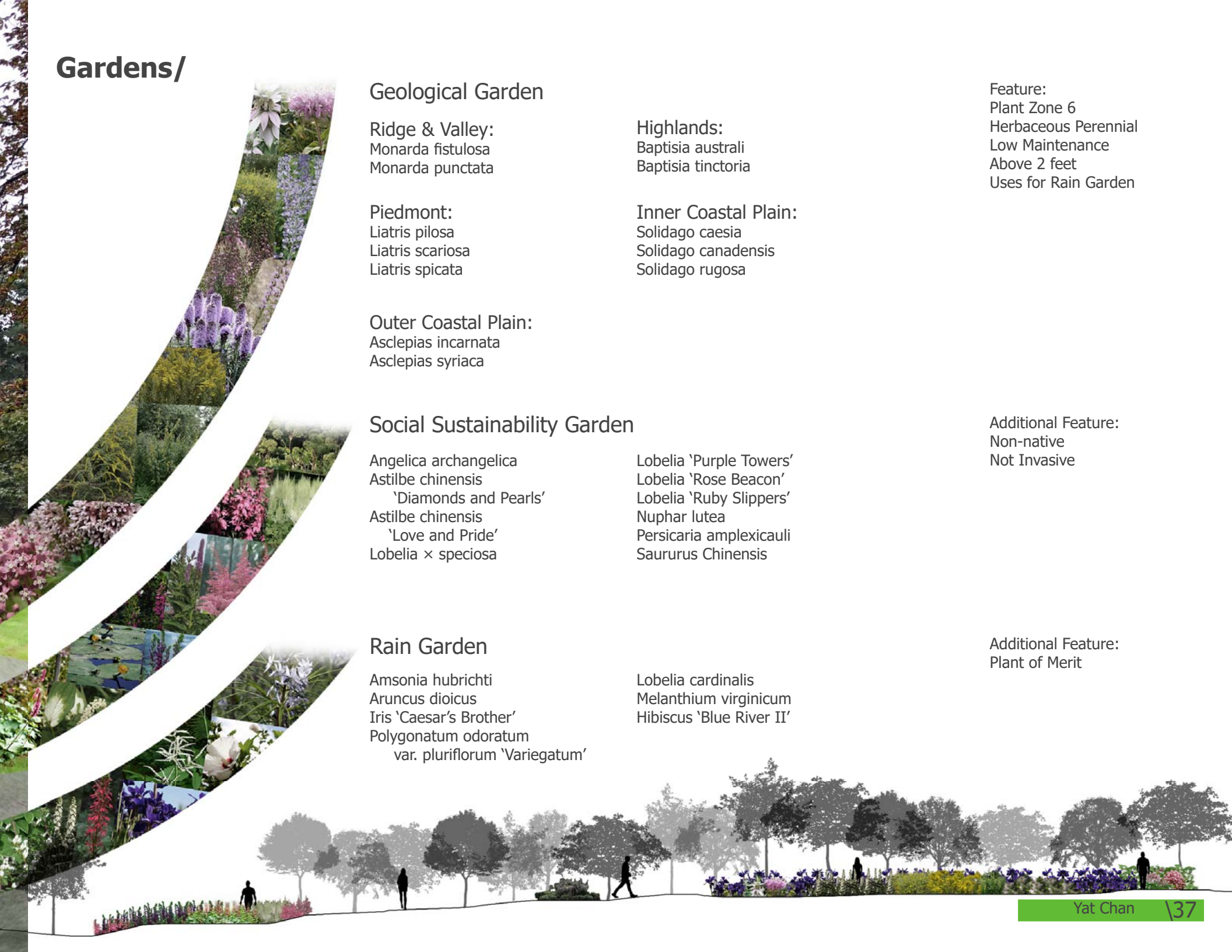

New Jersey Culture and Identity Gardens/

Our concept is driven by the consideration of all people in New Jersey. Our goal is to emphasize the changing cultural identity of New Jersey over time in this design.

As the centerpiece of present day identity, the Italianate garden has been transformed into the Gender and Sexuality garden. The garden's formal layout is maintained, but the plant palette alludes to its new cultural reading. This garden features two species inherently important to the inclusion of all peoples in New Jersey and America, Sweet Flag // *Acorus calamus* as well as the Common Blue Violet // *Viola sororia*. These two plants represent the LGBTQIA+ community in literature and symbolize the need for inclusion of people who have been historically discriminated upon in America.



Gender & Sexuality Garden/ Meadow Sequence/

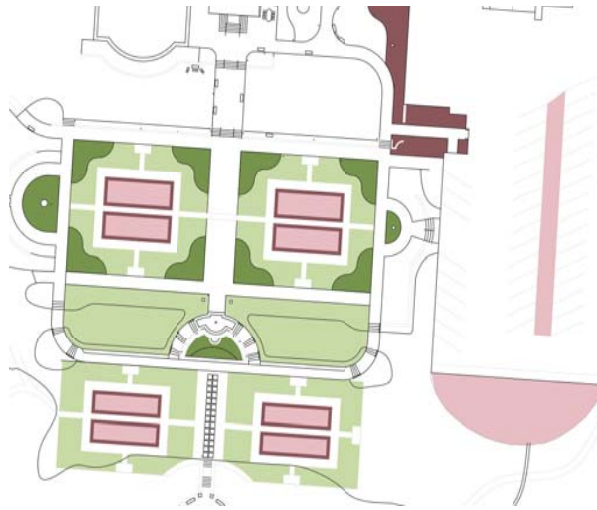

SWEET FLAG
Acorus calamus

Sweet flag is a plant native to Asia that has become naturalized in the United States. This plant is seen in literature as a symbol for same-sex love between two males, especially in Walt Whitman's poem, *Leaves of Grass #4*. The poem sequence describes a story of the writer and his male lover. The plant was chosen in the central spaces of the Italianate garden to represent peoples that have been and continue to be discriminated against in the United States. It is an interactive plant that gives of a fragrant scent when broken and has been used for medicinal purposes. *Acorus* is ideal for a rain garden, as it prefers to be saturated, and can take the shade of the particular garden location. For this reason, it has also been added to the parking lot rain gardens.



EXISTING PERENNIALS

Keeping the existing perennials in the Italianate garden will keep the variety of plants and spirit of the gardeners who have volunteered to work there prior to this intervention.



COMMON BLUE VIOLET
Viola sororia

The common blue violet, also known as the lesbian flower, is symbolic in LGBTQIA+ history dating from the 1900s, since lesbian women would give purple violets to the women they were wooing. They symbolize Sappho, an ancient Greek poet who is known to be a symbol of female homosexuality. *Viola sororia* is a native wildflower and can handle clay soils and shade, making them a great candidate for this area. The purple violets surround the sweet flag in the Italianate garden and frame the walk through the garden. The violets bloom all summer, giving rich interest to the garden.

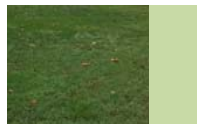

EXISTING LAWN

Keeping the existing lawn in the Italianate garden will keep the original formation of the garden and allow as a transition and walking space for visitors of Drumthwacket.

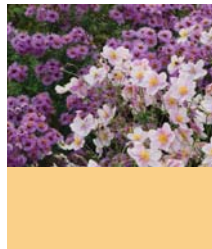

ELEGANS ANEMONE
Anemone x hybrida 'Elegans'
Native to Southwestern and Central China



VIOLETTA NEW ENGLAND ASTER
Aster novae-angliae 'Violetta'
Native to North America

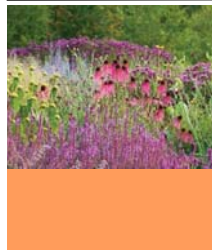

PALE PURPLE CONEFLOWER
Echinacea pallida
Native to North America



JERUSALEM SAGE
Phlomis russeliana
Native to Southwestern Asia

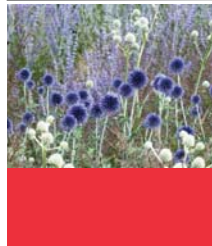

VEITCH'S BLUE GLOBE THISTLE
Echinops ritro 'Veitch's Blue'
Native to Southern and Eastern Europe and Western Asia



RATTLESNAKE MASTER
Eryngium yuccifolium
Native to Central and Eastern North America

RUSSIAN SAGE
Perovskia atriplicifolia
Native to Southwestern and Central Asia

From the rectilinear structure of the Gender and Sexuality garden, we transition towards the left of the garden to a meadow landscape with free-flowing, low-maintenance mown paths. While the meadow appears to be uniform, it is actually a collection of different meadow mixes, representing the varied demographics of New Jersey. The native grasses remain constant in terms of plant material, while the non-native forbs are varied to represent different countries of emigration, telling the cultural history of New Jersey immigrants in plant material.

In each pocket, a variety of plants from different regions are mixed, covering an array of regions. Some plants shown here are *Stachys officinalis* 'Hummelo', native to Africa, Asia, and Europe. We also have included *Eryngium yuccifolium*, native to Central and Eastern North America. The inclusion of plants native to various places of the world represents the melting pot that is New Jersey.

The pool and tennis courts have been transformed to refer to the agricultural history of New Jersey. A vegetable and fruit garden as well as an herb garden featuring plants to be used in the new farm-to-table Garden Scoop ice cream shop are proposed in this planting design. On days that the residence is open to the public, the shop will also be open to promote circulation to the western side of the site and act as an agro-tourism component of the Drumthwacket residence, recalling New Jersey's agricultural history.

Paths throughout the property are graded to follow ADA rules, to enhance the flow of travel and truly make it about the people. A path over a proposed stream, provides a connection between the sustainable parking lot and the frog pond.

Garden To Table

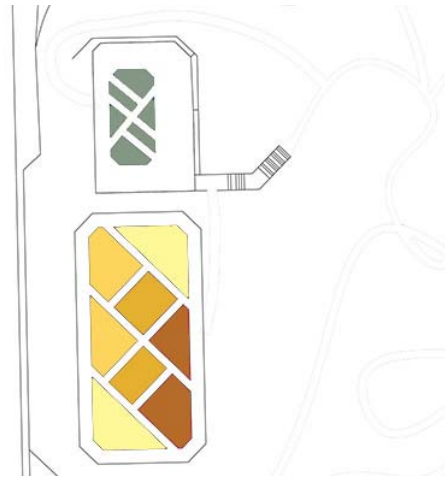

| | | | |
|---|--|--|--|
|  | SWEET CORN <i>Zea mays</i> convar. <i>saccharata</i> var. <i>rugosa</i> |  | SUGAR BABY WATERMELON <i>Citrullus lanatus</i> |
|  | GROUND CHERRY <i>Physalis peruviana</i> |  | ACORN SQUASH <i>Cucurbita pepo</i> var. <i>turbinata</i> |
|  | RED RASPBERRY <i>Rubus idaeus</i> |  | BLACKBERRY <i>Rubus fruticosus</i> |
|  | STRAWBERRY <i>Fragaria x ananassa</i> |  | BLUEBERRY <i>Vaccinium corymbosum</i> |
|  | LEMON VERBENA <i>Aloysia triphylla</i> |  | PHENOMENAL LAVENDER <i>Lavendula x intermedia</i> |
|  | CINNAMON BASIL <i>Ocimum gratissimum</i> |  | CHOCOLATE MINT <i>Mentha x piperita piperita</i> |
|  | SPEARMINT <i>Mentha spicata</i> |  | HONEY MELON SAGE <i>Salvia elegans</i> |
|  | STEVIA <i>Stevia rebaudiana</i> |  | ORANGE THYME <i>Thymus citriodorus</i> |



The Garden Scoop ice cream shop

Parking lot

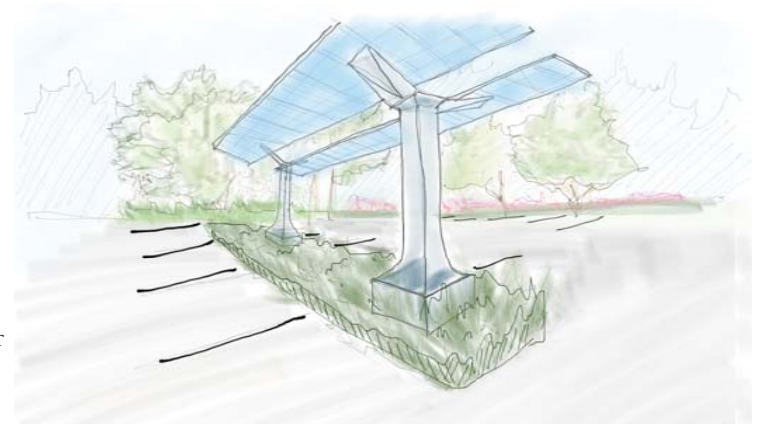

Solar Panels as overhead structures

Diagrammatic Garden Section/

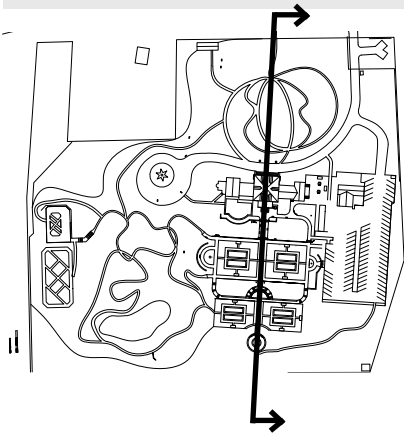
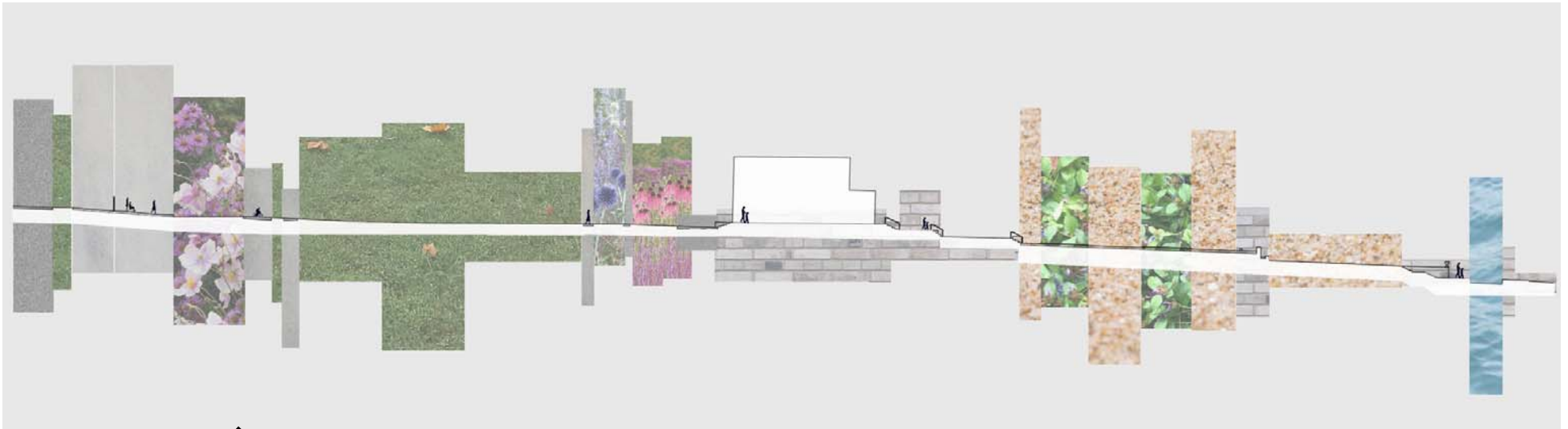

The parking lot has been redesigned to help with impervious surface runoff with the addition of a central and rear rain garden and solar panels over the central parking spots. There is an additional solar panel structure over the proposed bike parking near the side entrance of the residence.

The residence opens to the community with the addition of a walking gate and accompanying sidewalk in the front yard of the estate, leading right into the meadow paths. The gate stays open on days that the public is allowed access to the gardens.

This plan is intended to include all people and help them to feel more welcome in a community space. By opening up the space and making it walkable, as well as becoming an educational space for families about the inclusion of all identities, Drumthwacket can be a model for the modern suburban home as an environmentally and culturally sustainable space.

Participatory Art Landscape/

'Participatory Art Landscape' gives the site a new sustainable design and uses art to link people with nature. Drumthwacket becomes an outdoor art museum that celebrates nature and sustainability. The Italianate gardens are replanted as a formal garden with a new, native plant, meadow-inspired garden (see garden section--following).

EXISTING PLAN

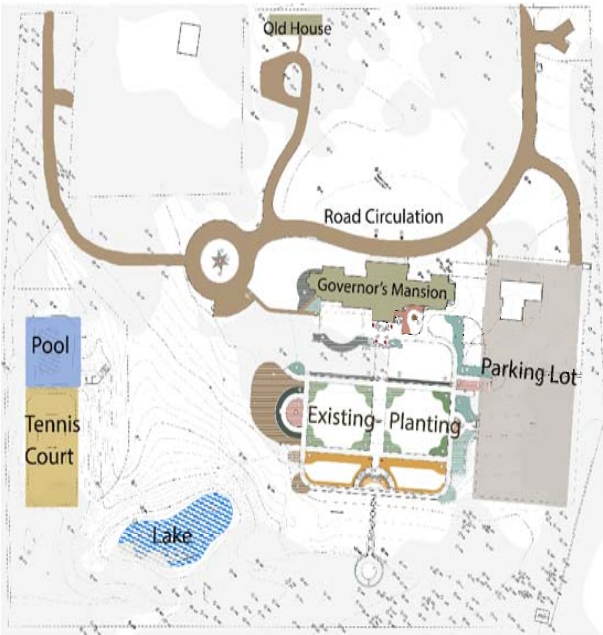

EXISTING PHOTO



Redesign Plan/



Section View/



Sustainable Meadow style Garden



Participatory Landscape with Sculpture

In Perspective/



Redesign the existing tennis court and swimming pool, building an amphitheater for holding events (afternoon musical appreciation concert, art open lecture and events for Drumthwacket Governor speaking).

Detail Exploration of Parking Lot/

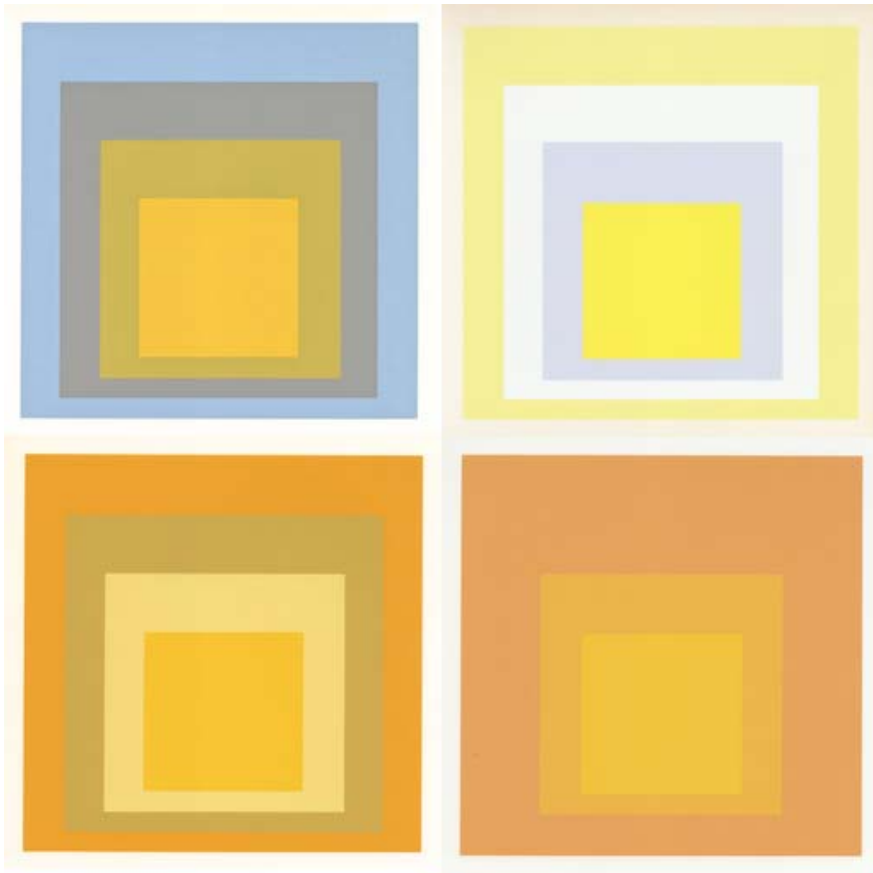

Homage to the Square by Josef Albers

Art Parking Lot/

Recalling an indoor modern art exhibition, the parking lot redesign references the art from Josef Albers "Homage to the Square," painted on the PlasticRoad recycled plastic parking lot that introduces the visitor to the art theme.

Description of the art: "Though the underlying symmetrical and quasi-concentric order of squares remains the same in all paintings – in proportion and placement – these same squares group or single themselves, connect and separate in many different ways."



Detail Exploration of Parking Lot/

Plastic Road Material/

Plastic Road, created by VolkerWessels Company consists of a prefabricated, modular and hollow road structure made from recycled plastic. It is low maintenance, fast installation and simpler and efficient compared to traditional road material.



Drumthwacket/

Reconnecting with:
Place,
People,
and Purpose

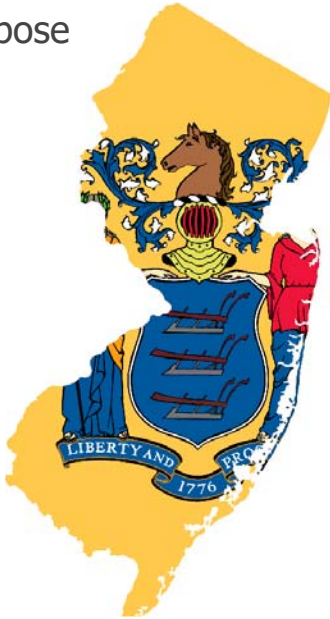

Drumthwacket is already located in an ideal area, with an abundant amount of land and opportunity. Not only does it have a strong past, but it has an even stronger, more sustainable future. In this proposal, Drumthwacket can once more be the community hub of Princeton, New Jersey.



What defines a place is the history it has, what continues to exist now, and how a place's history has influenced what it has become.

Design Exploration/

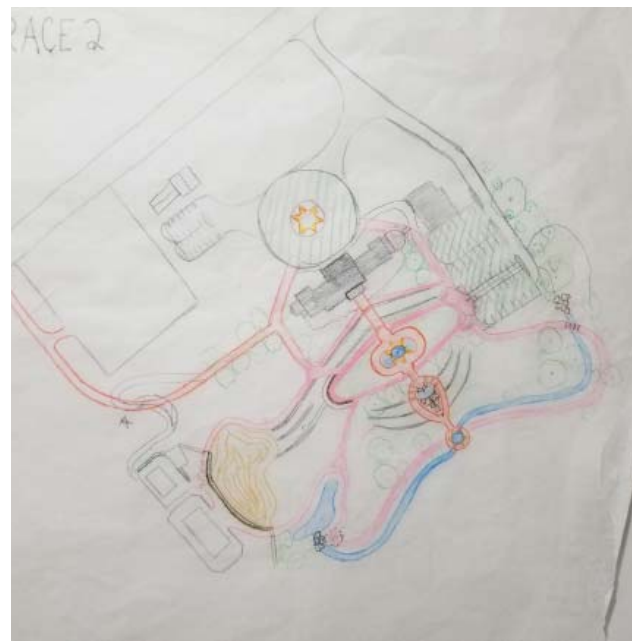

Through several iterations a final design balanced both the past and present while still maintaining the general Italianate structure. Diagrams explored spatial qualities and impervious surface cover, resulting in a smaller impervious footprint. Additional diagrams helped spatialize the design and provide a hierarchy of important design elements.

Reconnecting with Place/

Drumthwacket, just like many other places of historical importance, can be compared to a palimpsest, as it has been written and rewritten several times over. In order to connect to the roots of what this place is, one must go back to the times when this property represented the true potential of our state. The redesign as it is today, is a much less grandiose version of its prior counterpart. The original Italianate garden, complete with hedges, fountains and walking paths, showcased a time when the place was active and in regular use. Much of this has been stripped away, leaving the place barren and unfocused on anything except the path in front of you.

Today, Drumthwacket sits vacant, awaiting another new Governor with totally new ideas. Drumthwacket has the potential to represent the future of New Jersey, and showcase our pride in being a conglomerate of rich cultural history. Designing to unify spaces as we do people, and blend together landscapes has the potential to illustrate New Jersey in a new way. By bringing back existing elements more familiar to the garden it was meant to be, and creating spaces for both public and private use, Drumthwacket can be opened to the public, allowing more than just the Governor to enjoy this wonderful place. Additionally, by creating captivating moments and sightlines, people can once again experience this wonderful place.

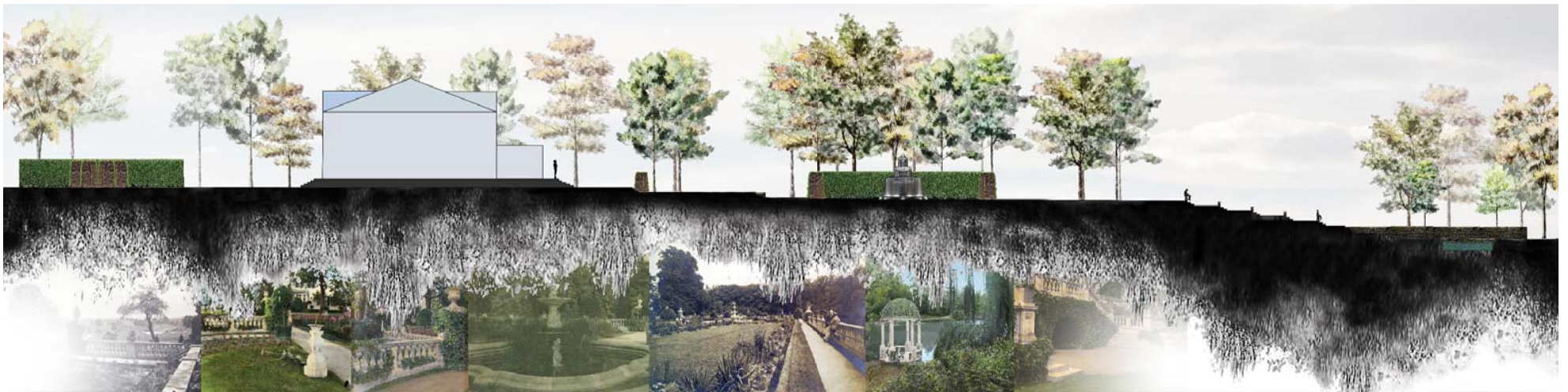

Reconnecting with Place/

Drumthwacket is also famously known for its six pointed star that used to be the centerpiece of the parties held there. Historically this was also the location of an old well that provided water to the property. This design abstracts this historic purpose and brings it to the surface by repeating the water theme along the main axis while also celebrating its original form. Today the well stands as the centerpiece of a driveway dropoff. In order to once again bring the focus back to this historically significant form, it is repeated three times along the main axis of the park. The first of which is the largest and is at the entrance in front of the building. The second is slightly smaller and holds the center fountain within its form. The last is simply reflected in the paving pattern by the frog pond.



People can explore the landscape here at their own leisure. For safety reasons, everyone should be eligible to be screened while on the property if it is deemed necessary by officials. While opening up the property could present potential safety risks, it is ultimately the people's house, and for that reason access should not be prohibited on weekends.

Reconnecting with People/

Once inaccessible to the public, Drumthwacket will now be able to be visited from Dawn until Dusk on weekends. By creating opportunities for people to visit, it opens up the possibility for programmed activities. Currently all of the gardening and upkeep is done by a few master gardeners. By allowing local children to garden and assist in the betterment of their community, we can instill the values of service and dedication to our future generation while also teaching them new skills. Educational courses and summer activities will be hosted by the Drumthwacket Foundation, and will serve as a channel for community outreach in schools. In addition to programming for children, the needs of the locals should also be addressed by hosting farmer's markets, annual celebrations and Flea Markets. Events such as these can bring popularity to a site like this and establish it as a hub for the community.

With the introduction of Public hours, the people of Princeton and the surrounding area will be within close walking distance of an open and interactive park. Bee boxes will be placed along the lake at the bottom of the hill and will provide a close home for pollinators seeking out nectar for their hive. They will also provide an interesting visual element, drawing people down from the garden to explore what the property has to offer. Along these walking paths, are several plantings of various types of native perennial meadow plantings.



Early Bloom

Wild Columbine- *Aquilegia canadensis*

Wild Lupine- *Lupinus perennis*

Late Bloom

Goldenrods- *Solidago* spp.

Black-eyed Susan- *Rudbeckia hirta*

Round-headed Bush Clover- *Lespedeza capitata*

Mid Bloom

Milkweeds- *Asclepias* spp.

Jewelweed- *Impatiens capensis* or *pallida*

Bee Balm, Wild Bergamot- *Monarda fistulosa*

Reconnecting with Purpose/

Because the future purpose of Drumthwacket is to serve as both a hub for the community as well as a place for private study and leisure, certain areas will be surrounded by hedges and will be gated during public hours on the weekend. These areas include the tennis and pool area, along with the private patio, located by the kitchen.



In an effort to make Drumthwacket more sustainable and improve the existing parking conditions, a number of solar panels will also be installed along the southern edge of the parking lot. This will provide shade for cars, renewable energy, and will further assist in shedding water from the hardscaped surfaces.

Although it is beautiful, Drumthwacket and its gardens are hardly innovative in terms of sustainability. Currently as they stand there is a huge problem with runoff. In order to revitalize the space and visually portray the movement of the water around the site, a man made stream is introduced where the existing drainage swale flows. Elevating this already naturally occurring process of runoff, and celebrating the water and it's function, activates and brings life to more than half of the site that is currently a flood zone. By eliminating hardscapes, and introducing bioswales and drainage areas, as much soil as possible is retained on site.



A Sustainable Garden/

A glimpse of Drumthwacket's new sustainable landscapes is given to passersby: a raingarden filters and slows street runoff along Mercer Road, and the teardrop-shaped mowed lawn is surrounded, unexpectedly, by a beautiful meadow to recall New Jersey's agricultural past.

Placing parking along the historical driveway loop outside the wrought iron fence devotes all of what we think of as the estate to a garden, creating a more sustainable Drumthwacket. The visitor parks their car outside the garden and enters the property from the west along the curvilinear driveway. To demonstrate sustainability, the driveway has a planted central strip, thus eliminating paved surface but remains functional so that visitors for formal functions can be dropped off at the main entrance. To limit paved surfaces, visitors to large events will utilize shared parking in the various local educational institutions.

Staff and family parking is organized efficiently around the garage, and the former parking lot is replaced by a secret garden, evoking aspects of historical Italian gardens to bolster the existing Italianate terraces. The secret garden gates can be left open to be discovered by visitors, or the Governor and his family can relax there in private when visitors are given access to the estate.

A woodland garden is created on the south edge of the estate to bring people to the pond and meadow walk, culminating in the renovated tennis court and pool area which end the visitor experience by providing a place for reflection and relaxation both indoors (visitor center with sustainability exhibits) and out (picnic zone).

The idea of a meadow landscape itself is very sustainable. With added stormwater drainage and designated trails, Drumthwacket can be a showcase for native New Jersey plants as well as an educational space for sustainability.

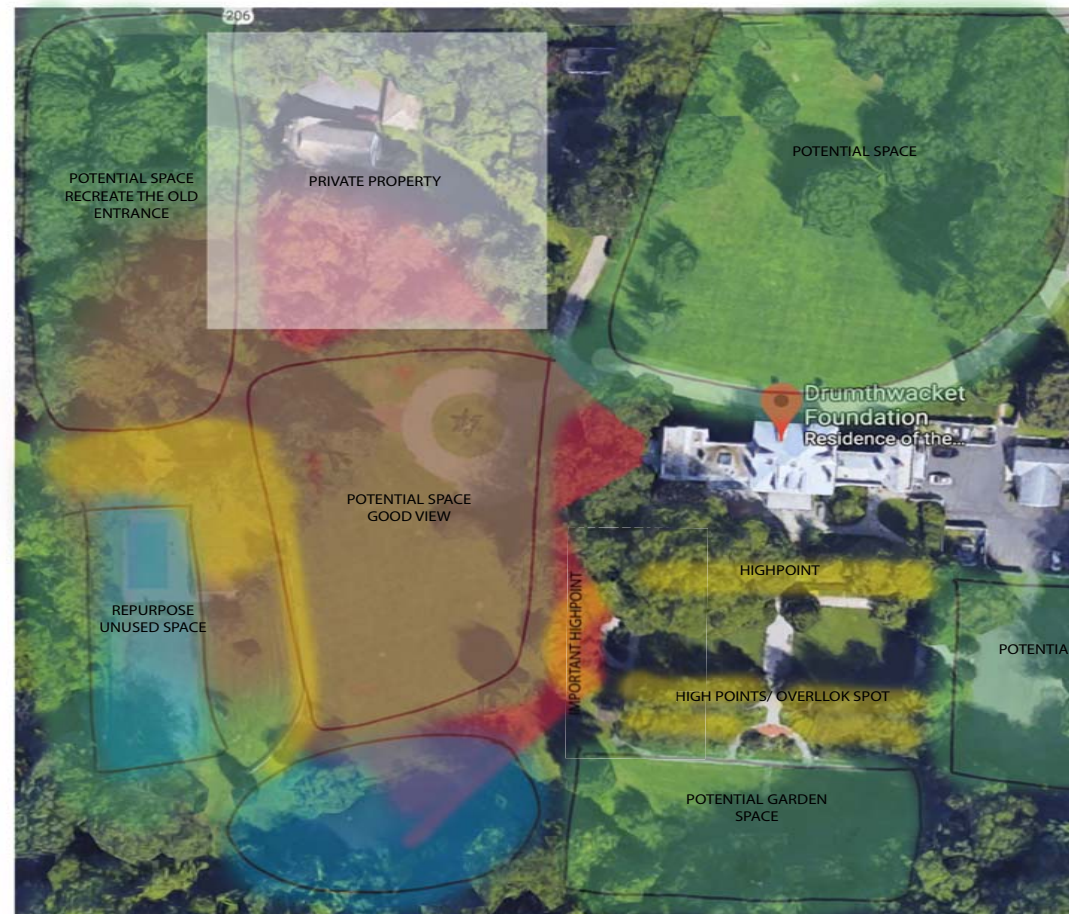

Site Plan/



- KEY**
- A. STAFF PARKING
 - B. VISITOR PARKING
 - C. ITALIAN GARDEN
 - D. FROG POND
 - E. RAVINE WALK
 - F. ENCLOSED GARDEN
 - G. MEADOW WALK
 - H. RETENTION POND
 - I. VISITOR CENTER
 - J. FRONT MEADOW
 - K. STREETSIDE RAIN GARDEN

Sections/

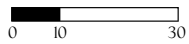
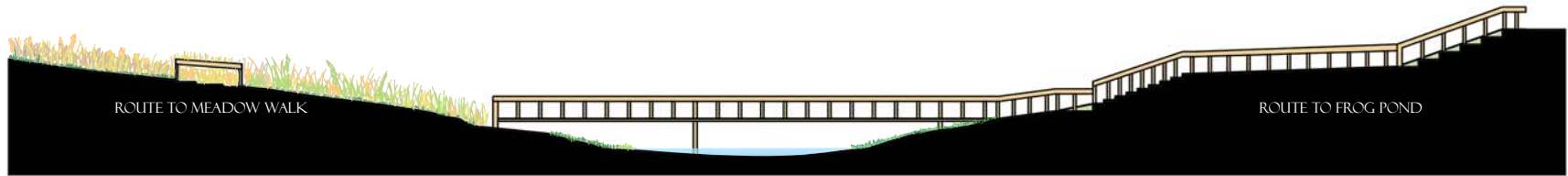
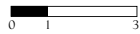
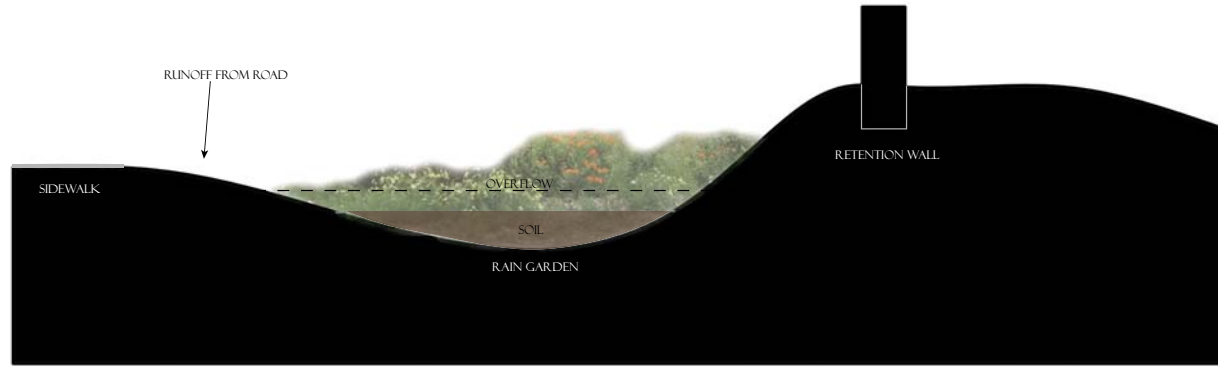

Meadow



Hairy White Oldfield Aster
Symphoricarpos pilosum
Perennial, flowers during fall



Little Bluestem
Schizachyrium scoparium
Blooms autumn



Bee Balm
Monarda fistulosa
Perennial, blooms summer



Foxtail Barley
Hordeum jubatum
Perennial, blooms early summer



Winkled Leaf Goldenrod
Salidoago rugosa
Perennial, blooms summer/fall

Garden



Culver's Root
Veronicastrum virginicum
Blooms summer



Eastern Red Columbine
Aquilegia canadensis
Perennial, blooms spring



Common Yarrow
Achillea millefolium
Perennial, blooms late-summer/fall



Flowering Dogwood
Cornus florida
Blooms spring



Foxglove
Penstemon digitalis
Blooms early summer

Visitor Ecological Center Perspective/



DRUMTHWACKET/
 PRINCETON, NEW JERSEY
 SUBURBIA TRANSFORMED
 FALL 2018
 WES MASCO

SITE ANALYSIS



- TREE CANOPY
- STEEP SLOPE > 3:1
- EXISTING CIRCULATION

I: WOODLAND OVERLOOK DECK

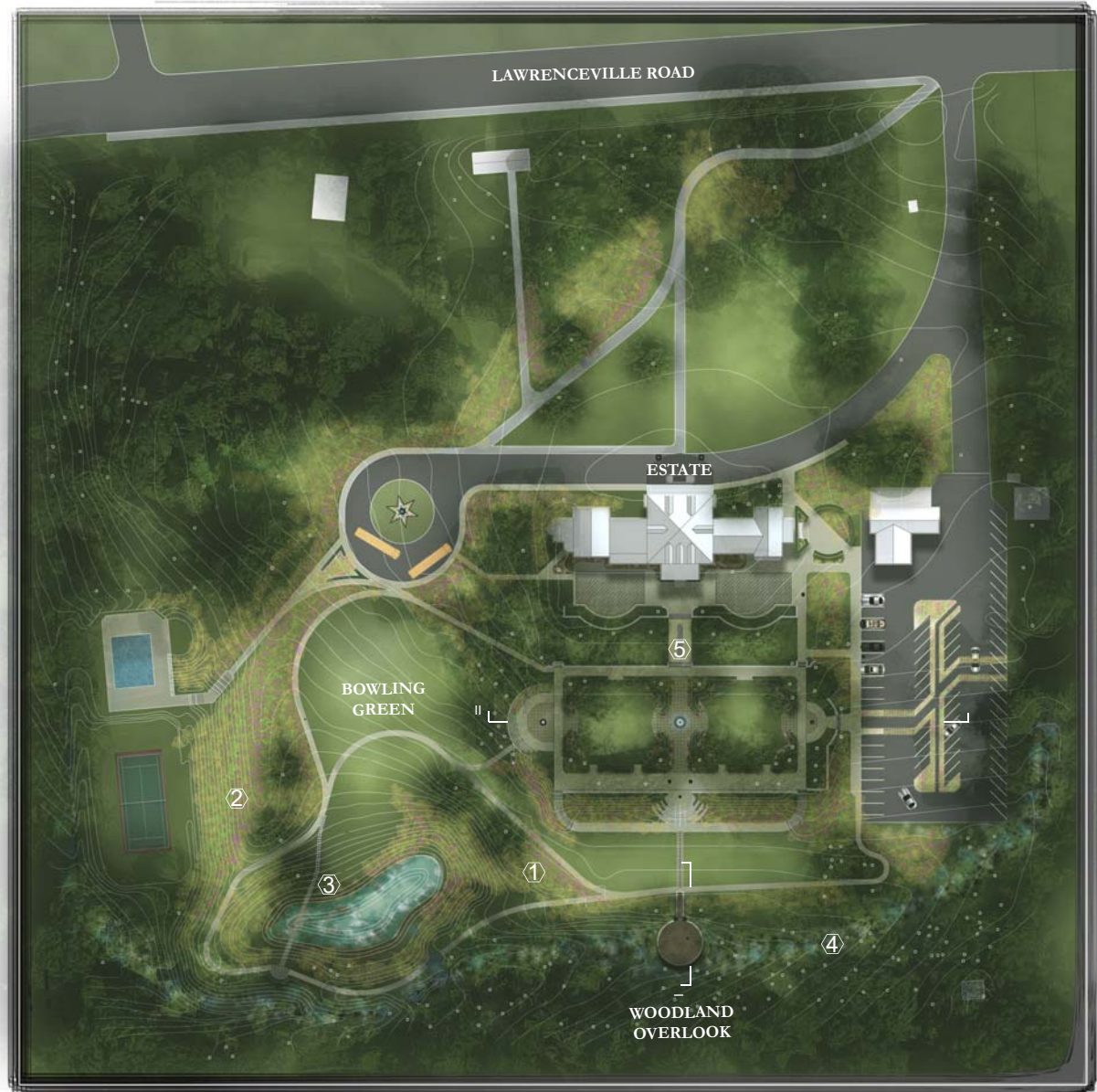

MASTERPLAN

SCALE: 1" = 40'

ECOTYPES/

DRUMTHWACKET: Wooded Hill: Regarded by Dugald Dalgetty as 'Hillock Called Drumsnab' Regarding the strategic **advantages** of a **wooded hill** in Scottish warfare

SUSTAINABILITY: Ability to **maintain change** in a balanced fashion, to a certain level or degree. Taking into account **social, environmental** and **economic** and factors

FOREST EDGE: The "Successional Edge" is a **dynamic space** rapid growth. Left unmanaged, the forest would creep on the open land. Removal of invasives allow native plants and trees to **flourish** and offer habitat for **local wildlife**.

GOAL: Expand the adjacent **forest edge** into the property by implementing a gradient of ecological habitats ranging from forest edge, meadow to wetland plantings. Simultaneously restoring historical aspects of the property's iterative past.

MODEL ECOTYPES

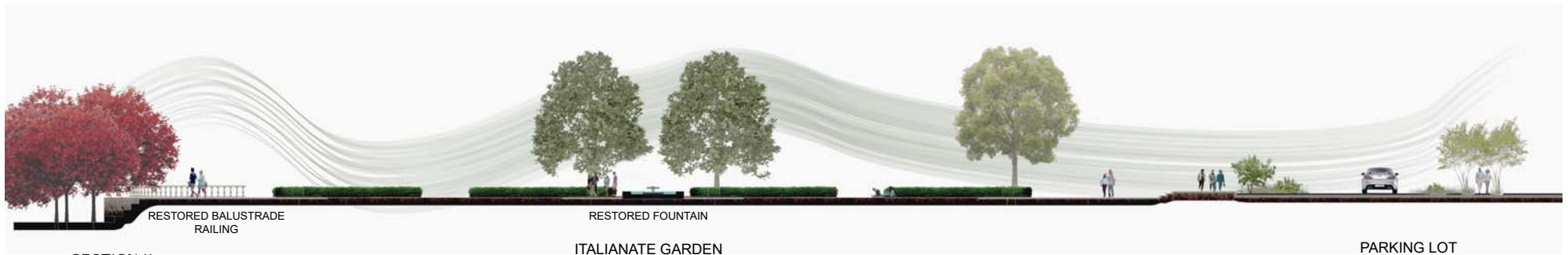
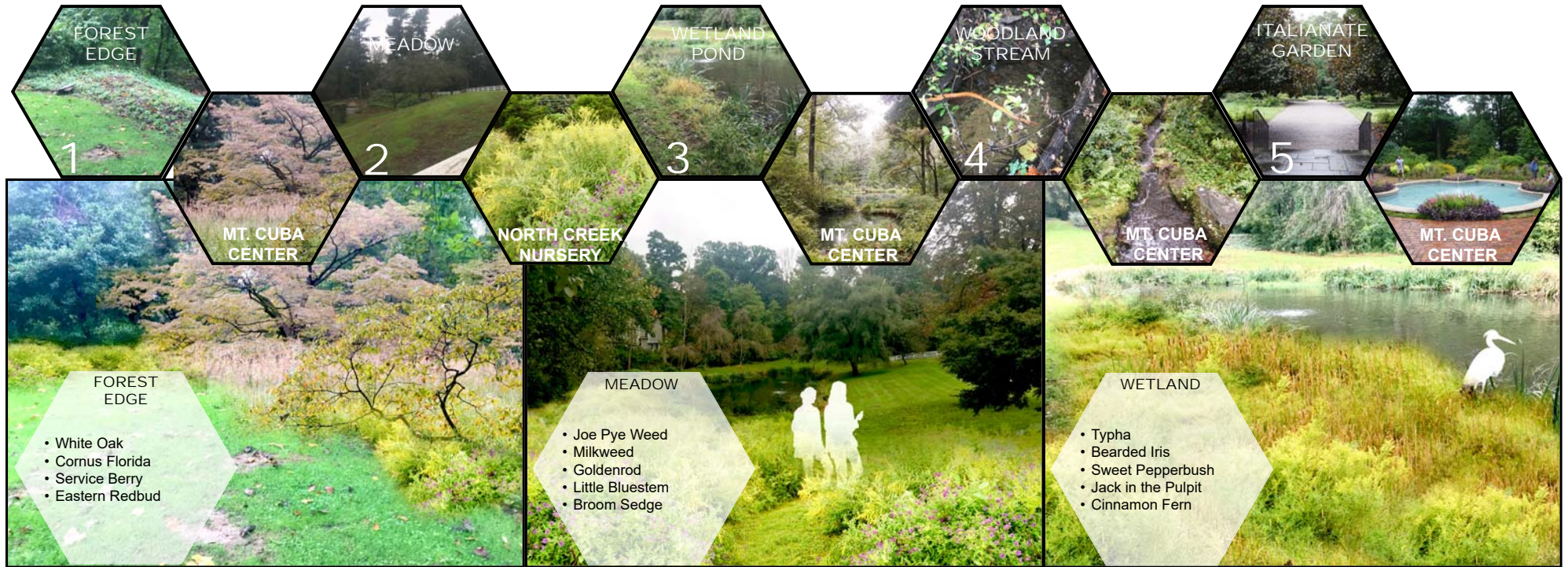

Drumthwacket: New Jersey's Diversity For Sustainability/

"Drumthwacket: New Jersey's Diversity For Sustainability" is a new face for the official residence of the Governor. It fore-fronts a new era for the Garden State, while bringing a new light to the people who inhabit it. The future of our state is in need of a new direction for green infrastructure and green technology. This redesign of Drumthwacket highlights the meaning of sustainability and how it can benefit the environment and accentuate natural, intrinsic beauty in the process. At the heart of this redesign lies a eye-opening concept that celebrates the diversity of New Jersey's immigrants. New Jersey is green, but it is also a diverse umbrella of unique individuals who stem from all over the globe. Diversity is a part of what makes the Garden State unique to this country. This redesign embraces and pays homage to those roots.

Studies on Green Infrastructure and Green Technology

Bio-Retention Swale



Mycoremediation is a fungi-based form of bioremediation used to decontaminate the environment. Fungi have proven to be effective and environmentally sound in removing toxins from the environment and wastewater.

Bio-retention swales are shallow, vegetated depressions in the landscape that are designed to manage stormwater by capturing, treating, and infiltrating the water as it moves downstream. Swales are flexible and can be used with a variety of plants and be implemented in many different settings.

Mycoremediation



Bryum caespiticium is a type of urban moss that has had a growing popularity for use in sustainable designs to filter stormwater. Due to its hardy nature, this moss can thrive in both sun and shade, and also can be grown in a variety of places.

Bryum caespiticium



Immigrant Diversity in New Jersey/

Data Provided By: Eagleton Program on Immigration and Democracy;
Eagleton Institute of Politics, Rutgers, The State University of New Jersey

New Jersey stands out for the diversity of its foreign-born residents

New Jersey

as compared to

the US

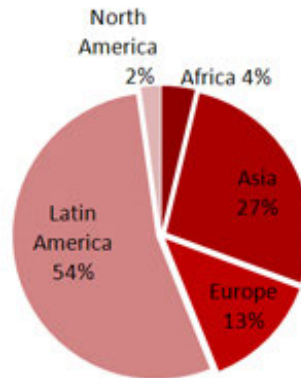
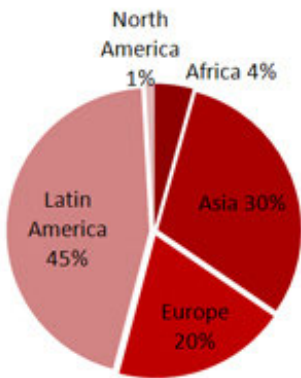

Historically, New Jersey is consistent in attracting immigrants more than any other state in the nation. On average, New Jersey's immigrants are more highly educated than those in other states. In fact, 48% of New Jersey residents with master's degrees and 41% of state residents with doctorates are immigrants. While today, the states largest foreign born populations come from: India at 10%, Mexico at 6.7%, and the Phillipines at 4.9%, the largest number of foreign-born residents are Latin American, Asian, and European.

New Jersey - Percentage of Foreign Born Population

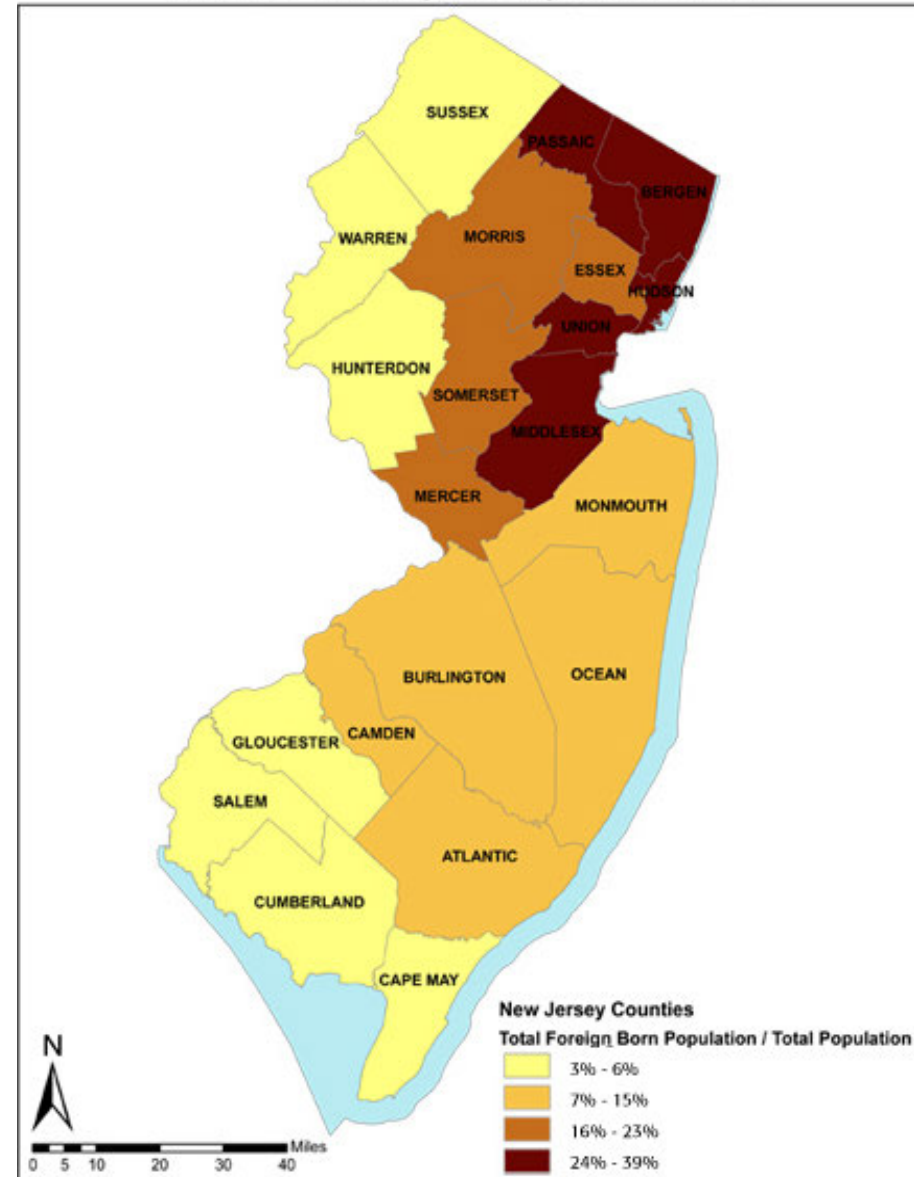

Drumthwacket: New Jersey's Diversity For Sustainability Plan/

The redesigned parking lot incorporates four components of sustainability: bio-retention swales, mycoremediation, "green strips" of *Bryum caespiticium*, and solar panels that also assist with drainage into the central swale. The combination of these components makes for a beautifully sustainable parking lot that is unique to both Drumthwacket and the Garden State. The front gate has been redesigned with changes in grade that replaces the fence with a stone wall, that does not obstruct the wonderful view of the front of Drumthwacket and still keeps deer out. Three "Immigrant Gardens" terrace downslope toward the pond as they highlight New Jersey's unique diversity. In addition, school bus parking has been added as well as an amphitheater space that can serve multipurpose events and programs.

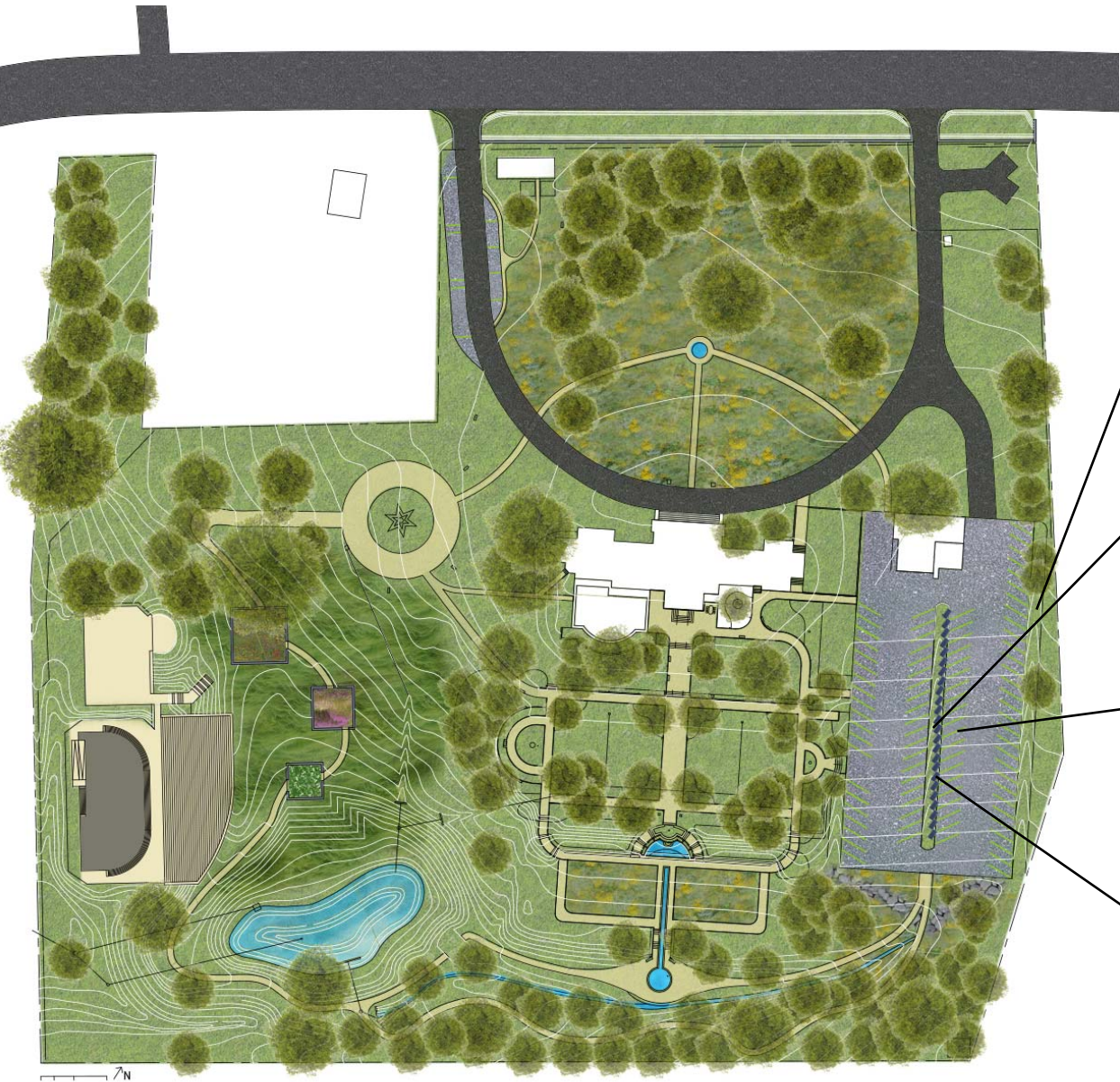

Bio-Retention Swale



Mycoremediation



"Green Parking Strips" using *Bryum caespiticium*

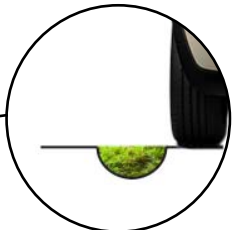

Solar Panels to assist with drainage



A Sustainable Front Lawn Fit For The Garden State/



Journey Through The Immigrant Gardens/



The Immigrant Gardens at Drumtucket represent the three largest groups of the state's foreign-born immigrants: Latin America, Asia, and Europe. The size of each garden correlates to the percentage of population of immigrants from each region. Each garden is a hidden treasure that houses plants that are native to each region. This celebrates New Jersey's immigrants as a reflection of the the state immigrant population, but it also brings to light the beauty of non-native plants because they too are a part of our population, and as a result, are just as valuable as New Jersey natives. Visitors can venture on a unique journey through Drumthwacket and see it not just as the official residence of the Governor, but also a reflection of our state and a statement for the future of sustainability in New Jersey.



Plant Palette For New Jersey's Immigrant Gardens/

Latin America



Puya mirabilis (Bromeliad)



Pennisetum alopecuroides 'Hameln'
(Dwarf Fountain Grass)



Tibouchina granulosa 'Kathleen'
(Pink Glory Bush)

Asia



Hydrangea paniculata
(Panicked Hydrangea)



Actinidia kolomikta (Variegated
Leaf Hardy Kiwi)



Asplenium antiquum
(Birds Nest Fern)

Europe



Betula pendula (Silver Birch)



Sambucus nigra (Black Elder)



Rhododendron luteum
(Yellow Azalea)



Technology of New Jersey: Integrating Innovation with the Past

Dianne Lê

What is time but a *social construct*?

We seek knowledge to better understand *how the world around us operates*,
And build machines to better use available resources to satisfy our needs.

We create years, months, weeks, days, hours, minutes, and seconds
In attempt to *organize the naturally occurring* dimension in which space moves thru,
Only to realize, inevitably, that time cannot be controlled
For it is *time itself that controls us*.

However, would you reckon that
Technology and innovation could just momentarily

Relinquish us from the unforgiveness of time?

[Historic Photographs]



Abram Spanel



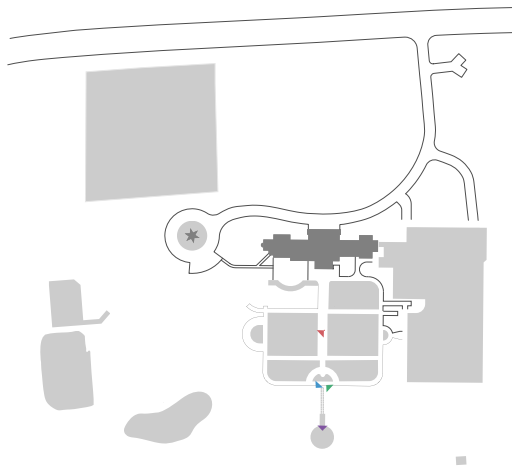

[Conceptual Diagram: Spaces]

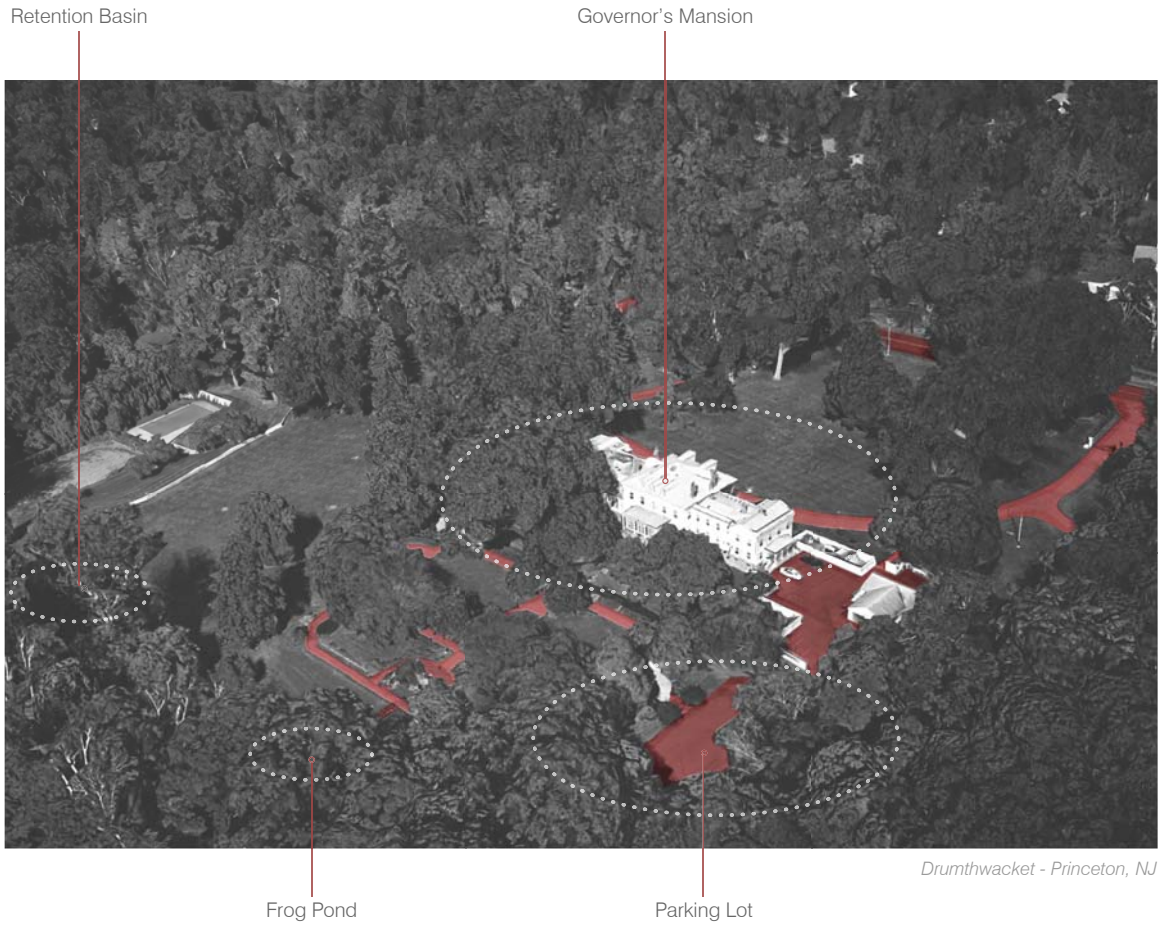

Drumthwacket - Princeton, NJ

Site Analysis - Drumthwacket: the site needs an aesthetic revamp to hold annual events for the governor of New Jersey, as well as an improved stormwater management system for the residence to become more environmentally sustainable.

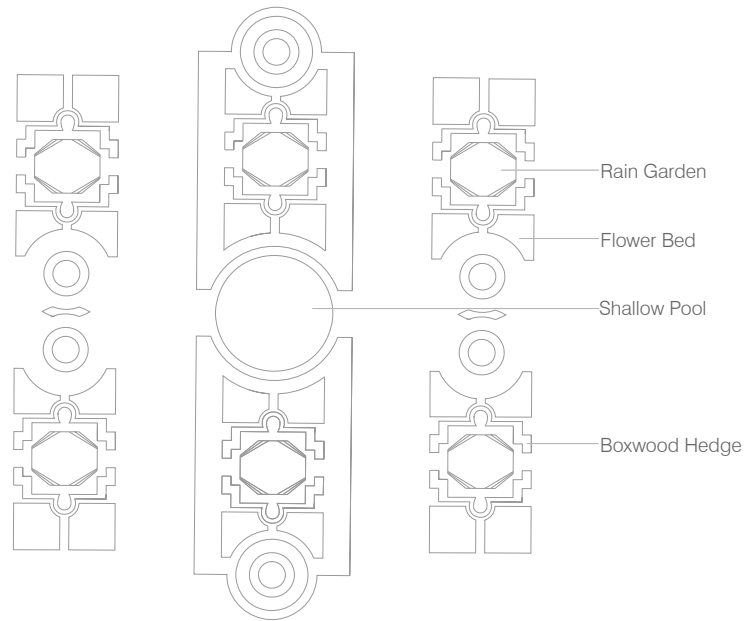

Parterre (above) - Inspired by electrical circuit boards, I have designed a parterre to be implemented in front of the Governor's Mansion. Bilaterally symmetrical and equipped with sustainable water features, this parterre will demand the attention and curiosity of visitors and those driving by the location. Furthermore, this parterre becomes only one segment of the central axis which runs through the the mansion and into the Frog Pond.

Electricity generating slide (top right) - As visitors (or the NJ governor) enter the slide, small rolling components will spin as the individual makes contact with them as they descend through the slide. These rolling components will be connected to a generator where rotational energy shall be converted to electrical energy and provide power to the fountain pumps, outdoor lighting, and support to the mansion electrical usage.

Hydrodynamic screw pump fountain (right) - Also commonly known as "Archimedes' Screw," this pump essentially transports liquids from a lower elevation to a higher elevation. This screw may be operated by a mechanical pump supplied by electrical or mechanical power (such as turning a connected wheel). This feature is intended to celebrate New Jersey's technological history while invoking curiosity in visitors.

Musical tiles (far right) - As one traverses following the grand axis behind the mansion and towards the Frog Pond, they will encounter interactive brass tiles which play different musical notes as visitors step on them. A classic, yet engaging feature for all ages and cultures.

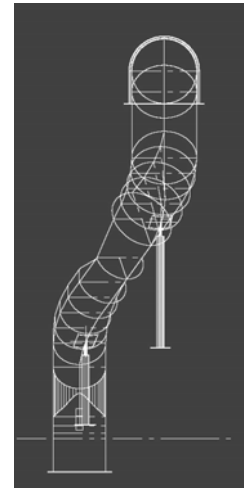
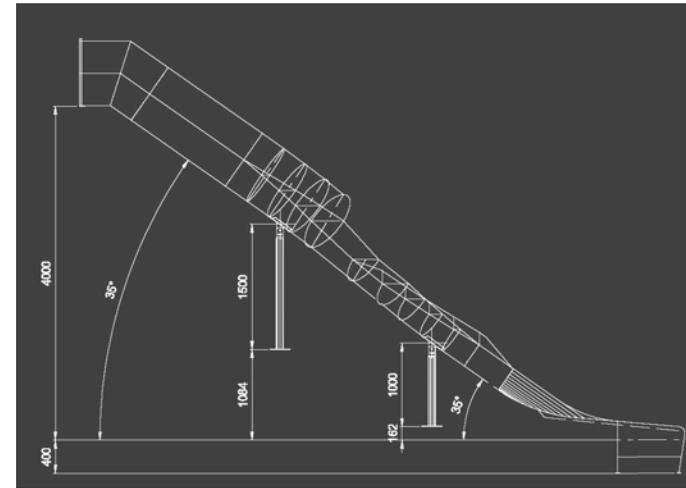

Drafted by Rohere Schale

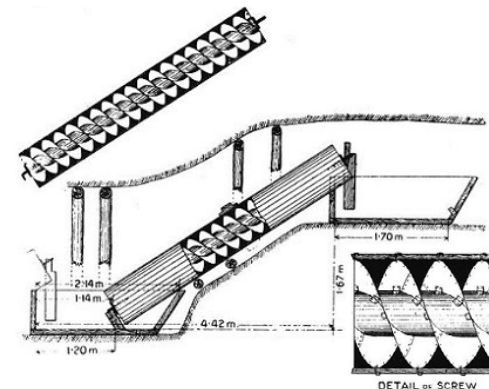

Technological Design Concepts



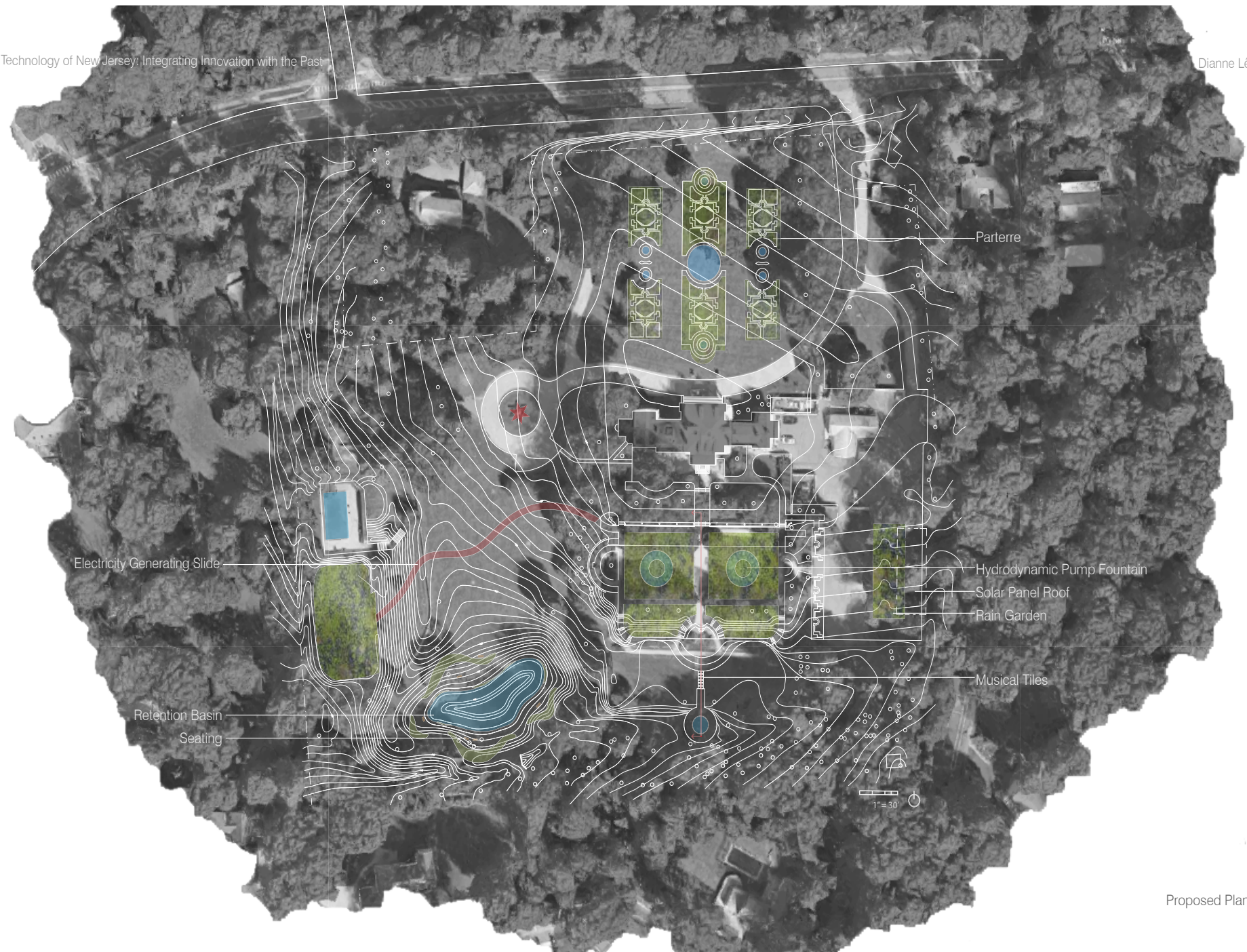

Proposed Plan

"We can only represent what we can imagine."

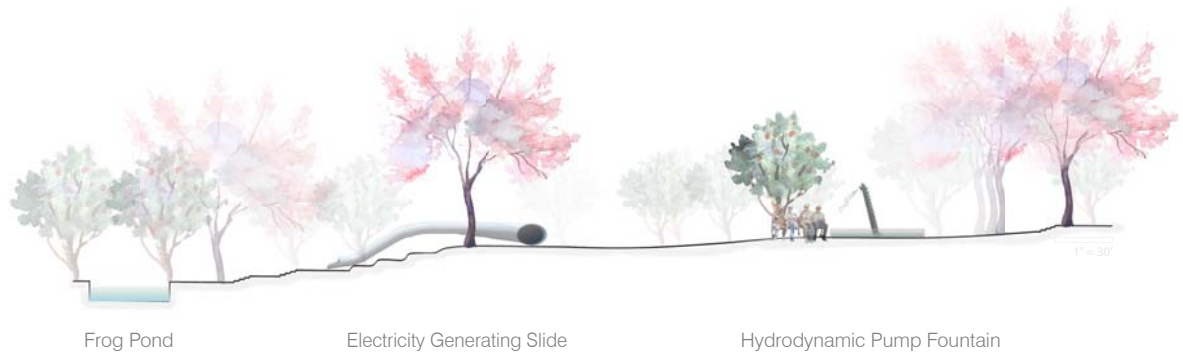

Proposed Section